

OWNER'S MANUAL



# SUPRA

*Launch 55 • Supersport • Launch 55D • Supersport D*

# DAILY CHECK LIST

## BOATMAN'S CHECK LIST:

For maximum enjoyment and safety, check each of these items **BEFORE** you start your engine:

- ✓ **DRAIN PLUGS** (Securely in place?)
- ✓ **LIFE SAVING DEVICES** (One for every person on board?)
- ✓ **STEERING SYSTEM** (Working smoothly and properly?)
- ✓ **FUEL SYSTEM** (Adequate fuel? Leaks? Fumes?)
- ✓ **BATTERY** (Fully charged? Cable terminals clean and tight?)
- ✓ **ENGINE** (In neutral?)
- ✓ **CAPACITY PLATE** (Are you overloaded or overpowered?)
- ✓ **WEATHER CONDITIONS** (safe to go out?)
- ✓ **ELECTRICAL EQUIPMENT** (Lights, horn, pump, etc.?)
- ✓ **EMERGENCY GEAR** (Fire extinguisher, bailer, paddle, anchor & line, signaling device, tool kit, etc.?)
- ✓ **BILGE PUMP** (Working properly?)

**NOTICE:** Bilge pump should be checked prior to each use to insure proper operation!

## CHECK BEFORE RUNNING:

1. Engine oil level.
2. Transmission Lubricant level.
3. Engine drain plug, transom drain plug and center drain plug.
4. Leakage (fuel and water lines and connections).

**CAUTION** DO NOT operate engine without cooling water flowing through water pump otherwise pump will sustain damage and subsequent engine damage may result.

## CHECK WHILE RUNNING:

1. Oil pressure: Refer to Engine Owners Manual.
2. Water temperature: 160° to 180° for raw water systems (water is not recirculated), and 180° to 200° for closed cooling systems (water is recirculated). Idle RPM: (550 - 600) in gear.
4. Maximum forward RPM: See Engine Manual.
5. Shifting linkage (forward, neutral and reverse).



**WARNING** It is very important to check for fuel spillage or leaks prior to each use of your boat.

Gasoline vapors can explode!

### Before starting engine:

- Check engine compartment for gasoline vapors.
- Operate blower for 4 minutes.
- Always operate blower below cruising speed.

**NOTICE:** Please refer to your Engine Owners Manual for maximum RPM and engine break-in procedure.

# SUPRA OWNER'S MANUAL

Welcome to the pleasure and distinction of Supra ownership. Supra inboard ski boats are manufactured by Skier's Choice, Inc. in Maryville, Tennessee and distributed throughout the United States and the world.

This manual should be considered a permanent part of your Supra. Should the boat be sold, this manual will provide the next owner with information on safety, operation and maintenance.

All information, illustrations and specifications in this manual are based on the latest product information available at the time of printing. However, Skier's Choice, Inc. of Tennessee reserves the right to make changes at any time without notice.

A maintenance schedule and accessory information are included in this manual. Warranty information regarding your Supra has also been provided to ensure your complete satisfaction should service needs arise.

This manual contains illustrations and references for several Supra models. Explanations for equipment and options not present on your boat may be encountered.

2001 Edition

## A WORD TO SUPRA OWNERS

To assure pleasurable and trouble-free operation of your boat, the Supra staff strongly recommends that you carefully read and familiarize yourself with all of the information and recommendations presented in this manual. Please keep this manual in a safe and dry place aboard your Supra as a permanent reference.

This manual contains suggestions to assist you in properly maintaining all areas of your boat. Drawings and explanations for accessories have been provided to acquaint you with all aspects of your Supra.

Should service problems arise, remember that your Supra dealer knows your boat best and would like to ensure your total satisfaction in our product.

Thank you for choosing a Supra product from Skier's Choice, Inc. We assure you that your boating pleasure and satisfaction will continue to be our primary concern.

## FUEL INFORMATION

- Use gasoline with a minimum octane rating of 89.
- DO NOT use gasolines containing alcohol, ethanol or methanol. Vapors from these gases are highly flammable and may damage the fuel system in your boat.
- It is recommended that gasoline types not be changed from one to another.
- Gasolines containing detergents, additives and stabilizers are safe to use.
- If storing for the winter or any period over 21 days, a gasoline stabilizer will reduce gum formation, varnishing and condensation which may affect starting and performance.

## MODIFICATION

Any modification of your Supra may affect performance, safety and durability and could void the warranty or violate Coast Guard or government regulations.

# INTRODUCTION

This manual provides an overview for operating your Supra boat. It describes equipment and gives specifications which were in effect at the time of printing. Supra may discontinue models and equipment or change specifications and designs without any notice and without incurring obligation.

As you read through this manual, you will find **CAUTION**, **WARNING** and **DANGER** logos which require special attention. Please read them carefully! They may tell you how to avoid problems and/or endangering yourself, your passengers, and other boaters.

This manual contains information about several Supra models. Some information may not apply to your boat since it will not have the equipment available on other models.

**⚠ CAUTION**

**⚠ WARNING**

**⚠ DANGER**

# TABLE OF CONTENTS

SPECIFICATIONS .....	6
TRAILER & TOWING .....	9
OPERATIONAL INFORMATION .....	14
INSTRUMENT PANEL & CONTROLS .....	21
EQUIPMENT AND OPTIONS .....	30
SERVICE AND MAINTENANCE .....	44
TECHNICAL INFORMATION .....	55
WARRANTY .....	57
CUSTOMER ASSISTANCE .....	60
INDEX .....	61

## BOAT SPECIFICATIONS:

	<b>Launch SS Sunsport</b>	<b>Launch SSV Sunsport V</b>
Length (w/out platform)	21'8"	21'8"
Length (w/platform)	23'8"	23'8"
Width (beam)	95"	95"
Draft	22"	22"
Standard Power (hp)	320 TBI	320 TBI
Optional Power (hp)	330 MPI	330 MPI
Weight (approx.)	3,200 lb	3,200 lb
Fuel Capacity	43 US Gal	43 US Gal
Seating Capacity	12	12



# LAUNCH SS / SUNSPORT

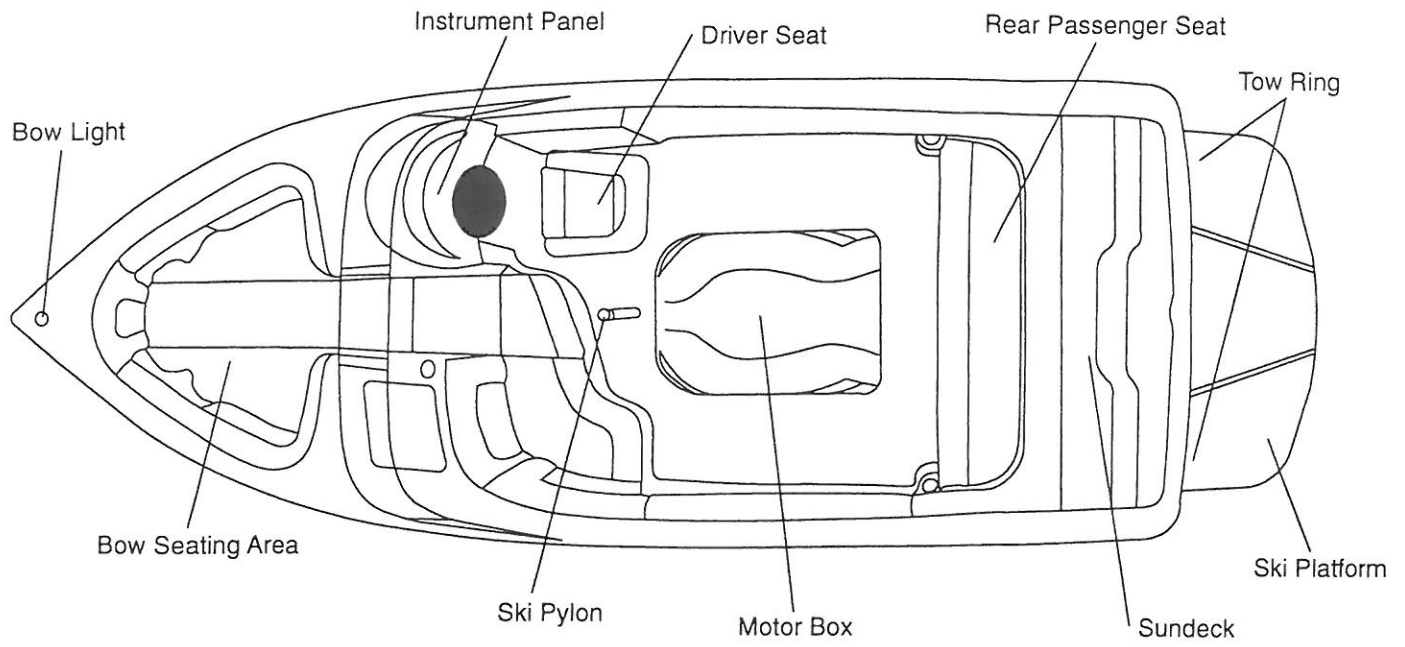

# LAUNCH SSV / SUNSPORTV

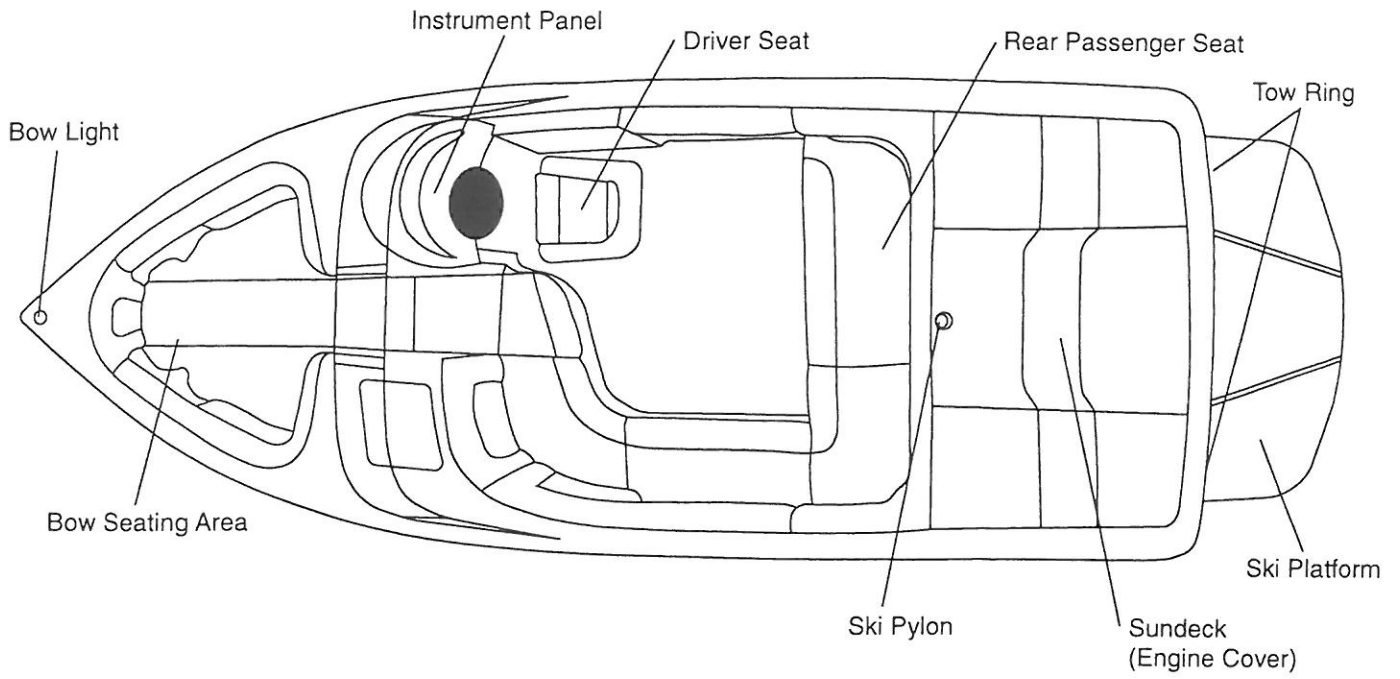

# TRAILERING & TOWING

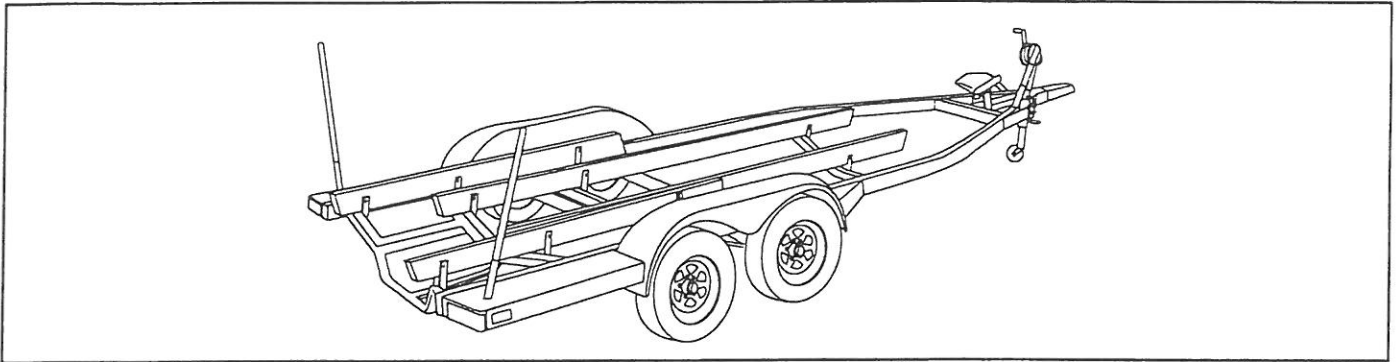

The trailer supplied with your Supra was designed specifically for the boat with your convenience in mind. The trailer includes several features, which maximize its performance and minimize maintenance. Please be sure that you have an appropriate tow vehicle before attempting to trailer your boat. Your vehicle must be capable of towing 5,000 lbs. and must be fitted with no less than a Class-III (5,000 lb MAX) trailer hitch.

**⚠ CAUTION** Read the trailer towing section of your vehicle's owners manual before towing your trailer.

All Supra trailers require a 2" ball and a 5-pin marine-grade wiring connector. The standard height from the ground level to the top of the hitch ball should be about 20 inches. With the trailer attached to the tow vehicle, the trailer should stand approximately level.

#### Trailer Plug Wire Schematic:

White:	Ground
Green:	Right Turn Signal
Yellow:	Yellow Left Turn Signal
Brown:	Running Lights
Blue:	Reverse Lights

**NOTE:** Your Supra trailer features disk brakes. The 5th wire on the wire connector (Blue) needs to be connected and your vehicle's reverse lights to be operative. This (Blue) wire provides power to a solenoid which deactivates the brakes while in reverse. You may still tow your trailer without the Blue wire connected; however, you may experience difficulty in backing up the trailer.

## CONNECTING THE TRAILER

When connecting the trailer to your tow vehicle, use the following procedure:

1. Raise the tongue with the trailer jack, position the trailer tongue directly over the 2" ball, and lower the jack until the tongue goes down all the way over the ball.
2. Press down on the latch until it locks on the ball with a "click". NOTICE: If your hitch ball has an excessive flat spot on the top, the latch may not engage properly. If the latch does not catch, check with your dealer or hitch installer before trailering.
3. Insert the locking pin into the tongue. (Lock pin hole is on the side of the tongue).
4. When all weight is off the trailer jack, pull the jack lock pin and rotate the jack to the horizontal position and re-lock the pin.
5. Attach the safety chains to the tow vehicle hitch. Cross the chains and wrap them around each other once or possibly twice allowing just enough slack to permit tight turns of the vehicle and trailer.
6. Connect the trailer light plug to the tow vehicle connection to activate the lights.

**⚠ CAUTION** BEFORE USE, READ ALL INFORMATION SUPPLIED WITH THE TRAILER BY THE MANUFACTURER!

The following guidelines will prolong the life of the boat and trailer:

1. Always secure the boat to the trailer with tie downs. Do not place straps around fenders or light mounts.
2. Before trailering, always attach the winch hook to the bow eye and tighten.
3. Check the recommended pressure displayed on the side of the tires and assure that it is maintained. Under inflated tires could cause trailer sway and excessive tire wear.
4. Before use, please read all information supplied with the trailer by the manufacturer (Bearing Buddy®, Boat Buddy® and hydraulic brake actuator). Check wheel bearing grease.
5. Before operating Boat Buddy®, check trigger setting and latch pin location. After loading, check latch pin and confirm that it is properly seated in the eye hook before pulling trailer out of water. Wash Boat Buddy® moving parts with high pressure water. Do Not Lubricate.
6. Check wheel bearing grease.

**⚠ WARNING** Inadvertent release of latch pin could result in injury.

## BOAT HOOKUP

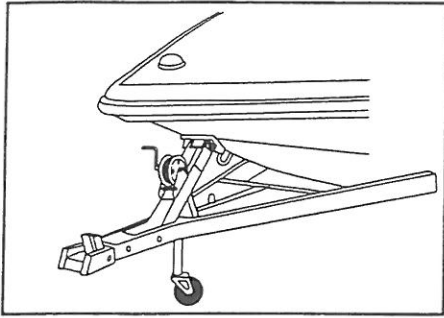

It is important that the boat is securely in place before moving the trailer from the water.

- Secure trailer hook to bow eye and tighten winch firmly.
- Check winch lock for secure placement.

## TRAILER ALIGNMENT

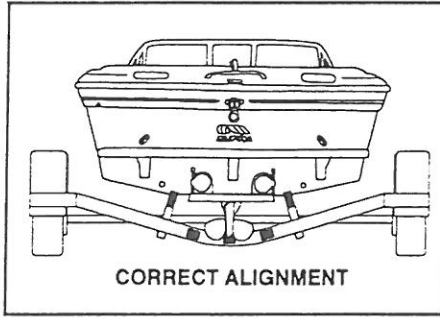

When pulling the boat onto the trailer, be sure that it is centered on the trailer.

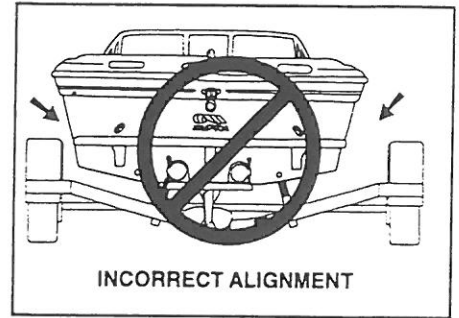

The distance between the boat and the wheel runner board should be equal on both sides.

## UNLOADING PROCEDURE

To unload the boat, refer to the following procedure as a guide:

1. Make sure that all of the drain plugs are securely in place. **Please refer to page 50 for details.**
2. Unplug light cord before backing into water.
3. With bow eye hook fastened, retract Boat Buddy® latch pin by pulling trigger into "safety" position. (If latch pin is bound, tighten winch to relieve pressure, then pull trigger into "safety" position.)
4. With Bow Eye Hook fastened, back the trailer until the water level is approximately 1 inch below the top of the trailer fenders. **NOTICE:** Ramp slopes vary, so actual level of water on trailer may be different. (NOTE: Warning on this page!).
5. Follow the cold start procedure recommended in this manual.
6. After starting the engine remove Bow Eye Hook.

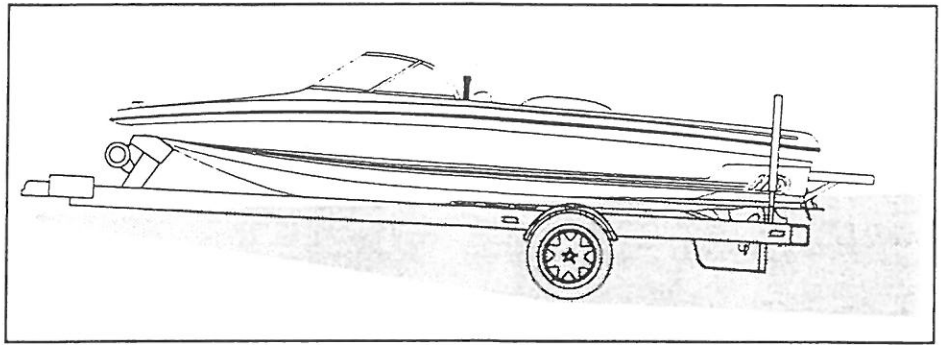

**NOTICE:** DO NOT attempt to use excessive power to free the boat from dry carpet runners. Power off of the trailer only when the boat has floated free.

**⚠ WARNING** If the trailer is not submerged to the correct depth, the bow of the boat could drop when powering off incorrectly, possibly damaging the boat.

7. With engine idling, center steering wheel, engage transmission and slowly pull throttle into reverse. Ease back on the throttle lever until the boat starts to move.

**NOTE:** Because your Supra is a direct drive inboard, when backing UP, the stern will have a tendency to drift left or right depending on propeller rotation. This condition will self-correct as the rudder reaches control speed.

## LOADING PROCEDURE

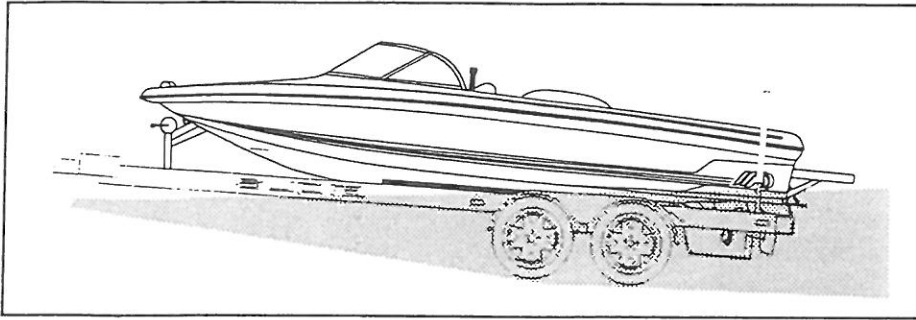

**⚠ WARNING** The trailer must be positioned for the correct water depth for loading or you may damage the boat. Varying ramp angles require different procedures. In general, the steeper the ramp, the more shallow the trailer should be positioned in the water. Your local dealer can help you understand this, should you require additional assistance.

To load the boat on the trailer, position the trailer in the water with approximately 1 inch of the top of the fender showing (as in step 3. UNLOADING Page: 11).

1. Set the boat Buddy® for loading by pulling trigger or latch mechanism into "set" position.
2. Idle/coast the boat onto the trailer using as little power as possible, while keeping it centered between the guide poles.
3. Power slowly forward until the bow eye solidly contacts the Boat Buddy® and the latch is triggered.
4. Winch hook must be attached to bow eye and tightened before trailering.

**DO NOT Power onto the trailer during rough conditions.**

Once correctly positioned on the trailer, switch off ignition.

**DO NOT OVER POWER** onto trailer or damage may occur to the boat.

# OPERATIONAL INFORMATION

## BREAK IN

Taking care now to properly break in your new engine will pay off in the long run. In our years of field testing, we have proven that an Indmar engine, when properly broken in according to our simple procedures, will last longer, run better and have fewer repairs over its lifetime.

Your new engine does not require an elaborate break-in procedure. Just follow these simple instructions and you are off to a great start.

The three (3) most important aspects of new engine break in are:

1. Avoid running engine at high speeds.
2. Do not carry a heavy load (passengers, gear, etc.).
3. Vary your boat speed during break-in, don't run at the same RPM for a long time.

### BREAK-IN STEPS

- For the first hour, do not exceed 2,000 RPM.
- For the second hour, do not exceed 3,000 RPM.
- For the next five hours, do not exceed 4,000 RPM.

### BREAK-IN TIPS

- Avoid fast accelerations and don't carry (or pull) a heavy load during this period.
- Always let engine warm up gradually before acceleration.
- Check oil frequently. During the first 50 to 100 hours, an engine can use more oil than usual. Maintain oil at a proper level at all times (do not overfill).
- Monitor transmission fluid levels.
- Report abnormal noises or vibrations to your dealer.
- Keep an eye out for loose mountings, fittings, nuts, bolts, and clamps.

During the BREAK-IN process, engine temperature should be carefully monitored and speed should be reduced if overheating is evident. **ALSO, PLEASE REFER TO ENGINE OWNERS MANUAL FOR BREAK-IN INFORMATION.**

**NOTICE: , PLEASE REFER TO ENGINE OWNERS MANUAL for maximum RPM and engine break-in procedure.**

After the first 20 hours of operation, take your boat to the dealer for its first oil and filter change, as well as an engine check up. Remember to keep a sharp eye on all gauges and warning lights during these first hours of operation. Report anything unusual to your dealer.

After the break-in procedure is over, your boat may be operated continuously at any speed.

**⚠ WARNING** Do not exceed maximum RPM recommended for your engine. Exceeding the maximum RPM may result in damage to the engine.

**⚠ WARNING** Before starting your engine you must open the engine box and check engine compartment and bilge for gasoline and oil vapors.



## STARTING & OPERATION

A standard pre-starting procedure should be always be followed before the first start-up of the day.

1. Check the engine oil level.
2. Check for gasoline fumes in bilge or engine compartment.
3. Operate engine blower for 4 minutes to remove any fumes.
4. Check manual operation of bilge pump. Make sure bilge areas are empty.

Other items might also be inspected, depending on the boat and its use. It is advisable to formulate a check list particular to the equipment and operation of your boat.

### **REFER TO THE BOATMAN'S CHECKLIST LOCATED ON THE INSIDE COVER OF THIS MANUAL.**

Consult the local Coast Guard Auxiliary or Power Squadron for full details on boating safety.

**NOTE: Add-on electrical accessories should never be connected to the ignition terminal or ignition circuit.**

**IMPORTANT: DO NOT continue to operate the starter for more than 30 seconds at a time without pausing to allow the starter motor to cool down for at least 2 minutes. This will also allow the battery to recover between starting attempts. PLEASE REFER TO ENGINE OWNERS MANUAL FOR ADDITIONAL DETAILS.**

### **BEFORE STARTING ENGINE, BE SURE THAT THE SHIFT SELECTOR IS IN NEUTRAL**

The correct starting procedure depends upon the type of engine. Please refer to the engine manual before starting.

## TO START ELECTRONIC FUEL INJECTION (EFI) ENGINE

1. Place shift selector in Neutral, with throttle in the upright (zero) position. **NOTE:** If throttle is not in the idle position, the throttle position sensor will not allow the engine computer to proceed with normal starting procedure.
2. Turn ignition key to the START position to operate starter.
3. Release the key when engine starts ( the key will automatically return to the RUN position).
4. Allow the engine to establish a good idle (30 to 60 seconds) before getting underway.  
**NOTE:** It is normal for the idle to speed up in cold start conditions.

### *IF THE EFI ENGINE BECOMES FLOODED*

1. Place the shift selector in Neutral and disengage the transmission by pushing the transmission lockout button located at the bottom of the lever.
  2. With the transmission disengaged, push the lever forward to full throttle position. This will cause the computer to shut off the fuel injectors, which will allow the engine to clear of excess fuel during starting.
  3. While holding the throttle in the full open position, turn the ignition key to the START position and operate the starter for no more than 15 seconds at a time until the engine starts.
  4. Once the engine starts, back off the throttle and allow the engine to establish a good idle (30 to 60 seconds).
5. Return the throttle to the IDLE position and the transmission lockout will automatically re-engage the transmission in neutral position.
  6. When ready to get underway, shift into forward or reverse, allowing the transmission time to engage the gearing before powering up.

## HOISTING

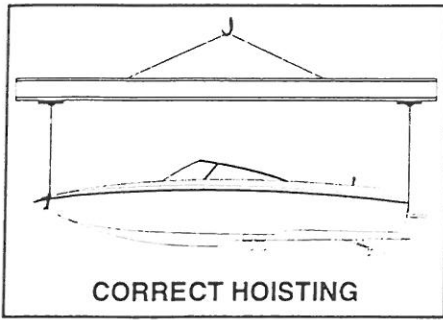

If the boat ever needs to be hoisted, special attention should be given to the following recommendations:

- Hoist the boat using a horizontal lifting bar only.
- Never attempt to lift the boat by means of a cable sling from bow to stern lifting eyes.
- Hoist operator should slowly and smoothly lift the boat without jerking to avoid damage to the lifting eyes.
- Use a clevis inserted through the lifting eye since a hook may damage the lifting eye edges.

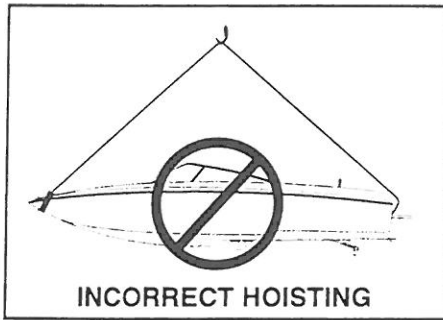

**⚠ WARNING** DO NOT use the ski pylon to hoist the boat.

**⚠ WARNING** Incorrect hoisting may invalidate the warranty on the boat.

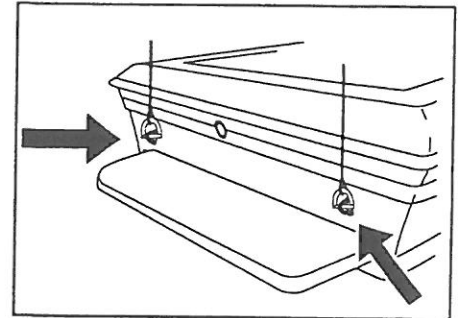
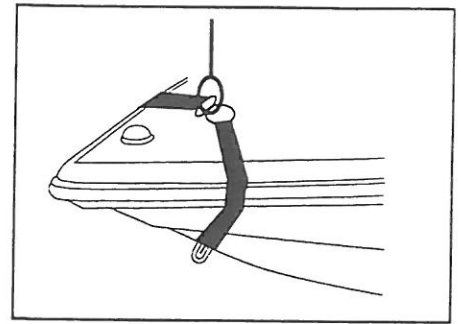

## WINTERIZATION & DRY STORAGE

When the boating and ski season comes to a close, it is recommended that your Supra boat be removed from the water and stored for the winter months.

**It is extremely important to follow the proper winterizing procedure. The engine must be correctly winterized for safe storage in your climate. This should be done by a professional. Your Supra dealer will know exactly what must be done to insure the longest possible life for your boat.**

In addition to preparing the engine, additional tasks will be required to insure proper winterization of the boat:

1. Remove the rear drain plug from the boat.
2. Thoroughly clean the boat inside and out. Inspect the hull for any residue or algae growth and remove as required.

3. Clean the bilge area thoroughly and operate the bilge pump to remove any water from the bilge hose.
4. Remove all seat cushions and open all storage areas to allow air circulation in the boat interior. When thoroughly dry, replace cushions and close storage areas.
5. Top off fuel tank to prevent any condensation from accumulating in the fuel system. Use a commercially available fuel stabilizer to remove water and prevent gumming.
6. If the boat is stored on its trailer, insure that the boat is properly positioned. If possible, lift the tongue so that the bow is slightly raised to promote drainage from the rear drain hole.

7. Install the canvas cover and secure the straps in accordance with cover instructions.

**NOTICE:** During the winter months, water is a boat's worst enemy. Only store the boat when the interior is completely dry. Periodically check on the condition of the stored boat.

**⚠ WARNING** The boat must be properly prepared and the engine properly winterized or severe damage may result.

## CANVAS COVER

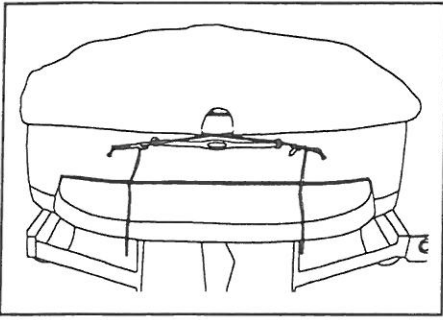

Your Supra boat cover is made from the finest canvas and webbing to insure that your boat will be protected in the off season. The cover has been designed to fit securely around each boat. If your new cover does not seem to be snug, a shrinkage allowance has been sized in.

Use the following procedure when covering the boat:

1. Be sure that the cover fits snugly at the bow then unfold from front to back.
2. Be sure to install cover pole(s) and adjust to proper height, using set screw on pole(s). This will keep water from gathering in the center, which can damage the cover.
3. Secure all fastening straps around the trailer frame.
4. Pull the draw cord equally from both sides and tie off to the lifting eyes on the stern in accordance with the illustration.

## FOLDING COVER

When folding the cover for storage, be sure the cover is dry. Take care not to scratch the canvas finish against rough surfaces. Store in a dry location.

## COVER REPAIR

If the cover becomes damaged, immediately patch and reseal the area. Use a tent seam sealer to reseal any new stitches. Spray fabric guard on scraped or worn surfaces. Canvas tears should be repaired professionally and stitches sealed to prevent leakage.

## MAXIMUM CAPACITIES

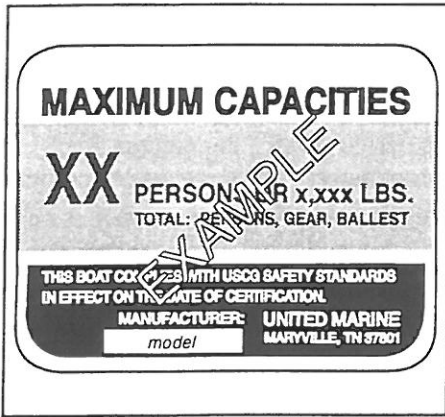

In compliance with United States Coast Guard Regulations, Supra Boats meet or exceed all safety standards designed for recreational boats. To insure safe handling and performance, each Supra boat displays a maximum capacity sticker (see sample), stating the maximum passenger weight load allowable.

**NOTICE:** Refer to the Maximum Capacity Sticker on your boat for allowable loading.

## COAST GUARD REGULATIONS

The United States Coast Guard Boating Regulations prescribe minimum standards of safety and it is necessary that your boat remain in compliance with these regulations.

## SAFETY PROCEDURES AND EQUIPMENT

The following equipment should be on board your Supra at all times:

- An approved hand-held fire extinguisher (provided with your new boat).
- At least one USCG approved Personal Flotation Device for each person aboard.
- At least one approved throwable device (ring buoy or buoyant cushion).
- One hand-, mouth-, or power-operated whistle or horn, audible for at least one mile.
- Signal flares should be carried by boats going offshore.
- In addition it is recommended that you carry an anchor, anchor line, docking line, boat fenders, first aid kit, water-proof flashlight, emergency tool kit and electrical tape.

# INSTRUMENT PANEL & CONTROLS

## DASH PANEL LAYOUT

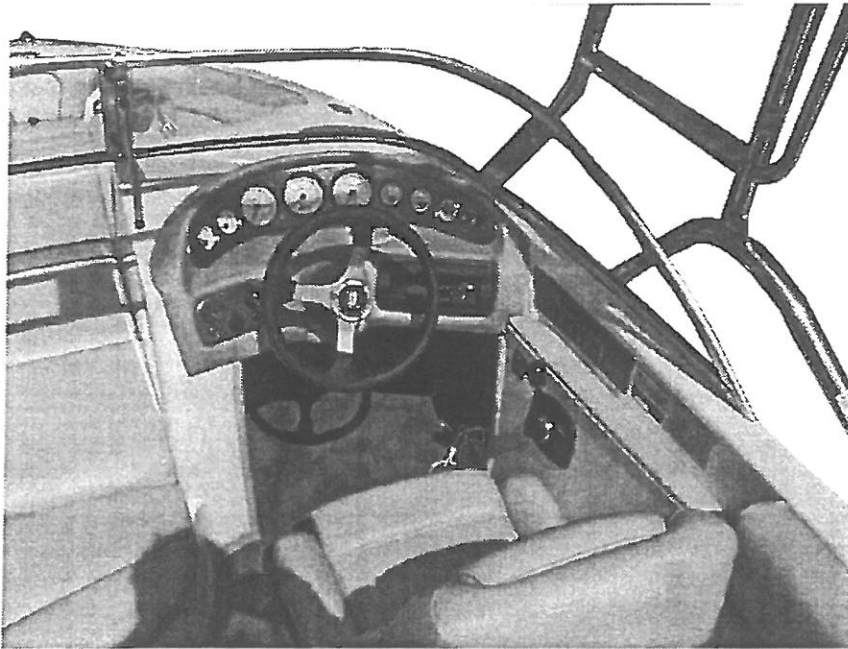

## SPEED CALIBRATION

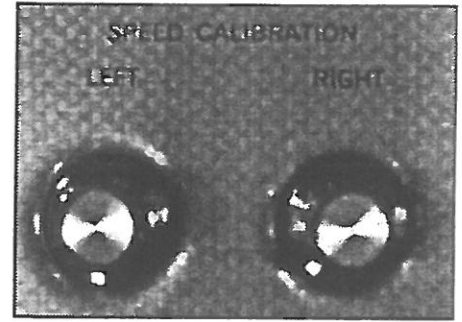

Speed may be checked using a stopwatch and a standard slalom course. Adjust the speedometer needle by turning the adjuster buttons.

### SLALOM COURSE SPEEDS:

MPH	SECONDS	ALLOWABLE
+ or - 1/2 MPH		TIMES / (SECS)
18	32.19	32.0 - 32.6
20	28.97	28.0 - 28.6
30	19.31	19.0 - 19.6
32	18.11	17.9 - 18.3
34	16.95	16.8 - 17.2
36	16.08	15.9 - 16.3

## SPEEDOMETER

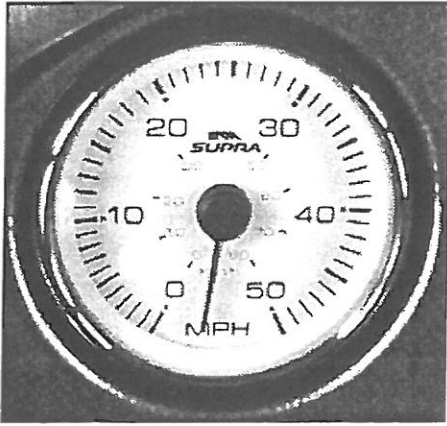

The speedometer indicates the water speed of the boat in miles per hour. It is recommended that the speedometer be checked for accuracy after each 100 engine hours.

## TACHOMETER

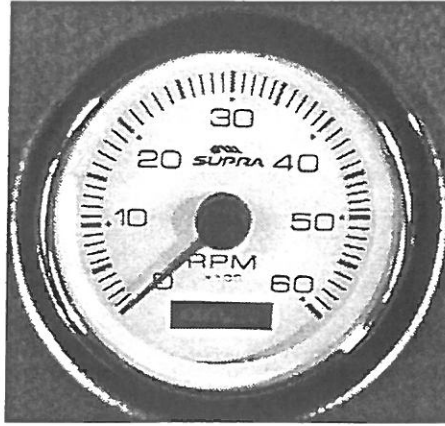

The tachometer registers the operating speed of the motor's shaft output. It may be used as an alternative to speedometer if weight and water conditions permit.

**DO NOT** exceed the recommended RPM during break-in and normal operation of your motor. Exceeding the manufacturer's suggested RPM may cause damage to the engine.

## ENGINE HOURS

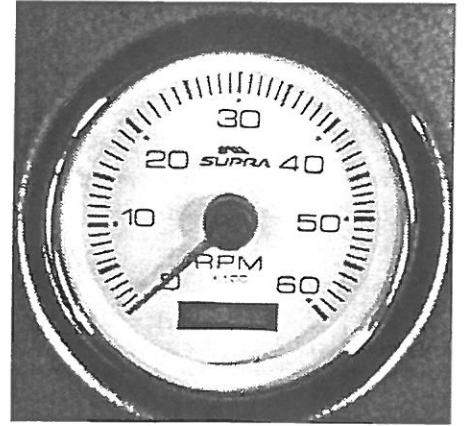

ENGINE HOURS are shown on the face of the TACHOMETER.

The engine hour gauge acts as an odometer for the engine. Engine hours should always be noted and documented so that required maintenance and lubricant changes may be performed at the proper intervals.



## THROTTLE LEVER

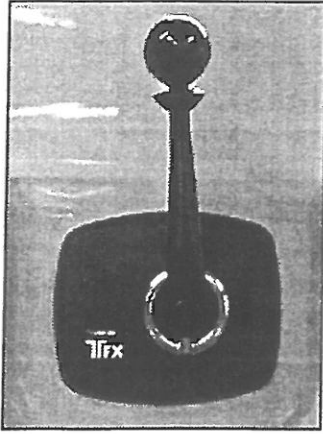

The throttle lever controls both the throttle and the transmission. The idle position (normally vertical) is the zero throttle position and the neutral position for the transmission. A safety ring keeps the lever from being accidentally moved to engage the transmission. To place the transmission into gear, place your hand over the lever ball, pull up on the safety ring and slowly push the lever into forward gear or slowly pull the lever back into reverse gear.

**⚠ CAUTION** Never shift the lever directly from the neutral (vertical) position into a speed position. To prevent damage to the transmission, always allow the transmission time to engage before accelerating the engine. Once the transmission is engaged, you may accelerate as quickly as you would like.

## V-DRIVE WARNING LIGHT

The V-drive transmission in your Santera is equipped with a "low pressure" warning light. This light is located below the throttle lever. Do not operate your Santera if the warning light remains on, whenever the engine speed is above 1,200 RPM (+/- 400 RPM). This warning light should be on if whenever the engine speed is below 1,200 RPM (+/- 400 RPM). If this light remains on during operation above idle, shut your engine off immediately and check your transmission fluid level or see your dealer.

23

## TRANSMISSION LOCKOUT

The Transmission Lockout button allows the transmission to be disengaged while giving the throttle full operating range. With the lever in the idle position (normally vertical), push the button located at the bottom of the lever to disengage the transmission. The throttle may then be operated in any position (forward of neutral or back of neutral upright position). Return the throttle to idle position and the transmission lockout will automatically re-engage the transmission in neutral position.

## IGNITION

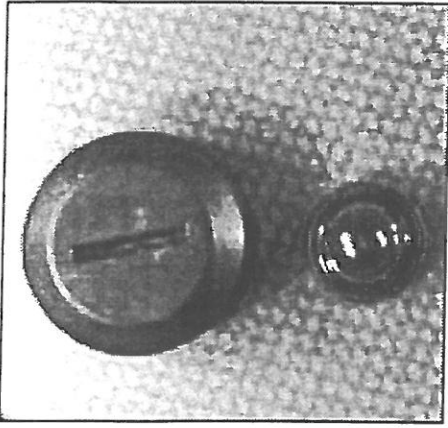

The ignition is located to the left of the steering wheel. Follow starting procedure outlined in this manual.

## DC OUTLET

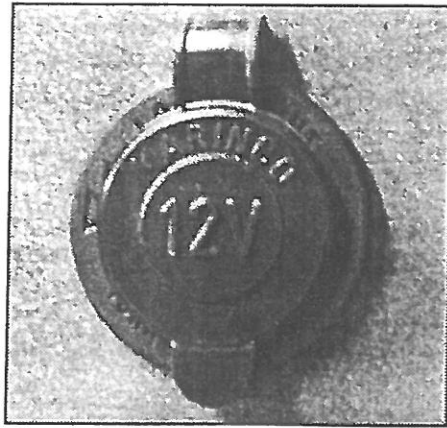

For your convenience a DC outlet has been included next to the ignition switch.

## WARNING LIGHT



The warning light should be "on" at idle. If the light remains "on" when the engine is above 1200 RPM, shut engine off and check V-Drive oil level.

## TEMPERATURE GAUGE

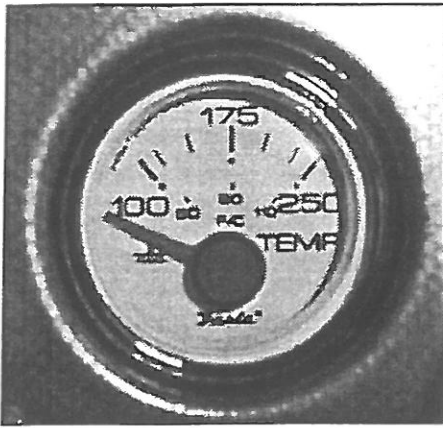

The temperature gauge indicates the engine coolant temperature while the coolant is circulating inside the engine. Engine operating temperatures will vary depending on the weather conditions and engine load. Normal operating temp range is between 160° and 180°.

**NOTICE:** Refer to your Engine Owners Manual for additional details.

## FUEL GAUGE

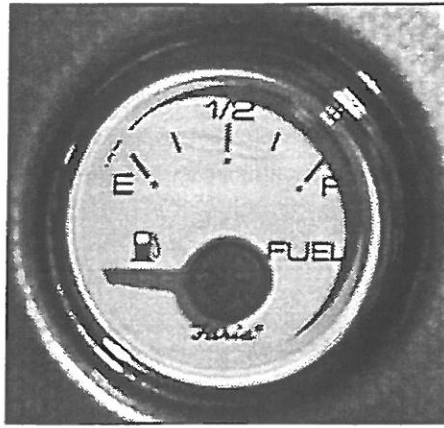

This gauge indicates the approximate quantity of fuel remaining in the tank when the ignition is in the "ON" position.

**NOTICE:** DO NOT run the tank to empty. To prevent condensation from forming in the tank, it is recommended that the tank be filled when the gauge indicates 1/4 tank of fuel remaining.

The following conditions may be considered normal operation of the fuel gauge and fuel system:

- Gas station pumps may shut off before the fuel gauge indicates FULL.
- The amount of fuel required for fill-up may not exactly correspond to the gauge.
- The gauge needle may not move away from FULL until some time after fill-up.
- The gauge needle may move during turns, stops and acceleration.

**NOTICE:** Become familiar with engine hourly fuel consumption at various speeds and know when to check the fuel gauge.

## VOLTMETER

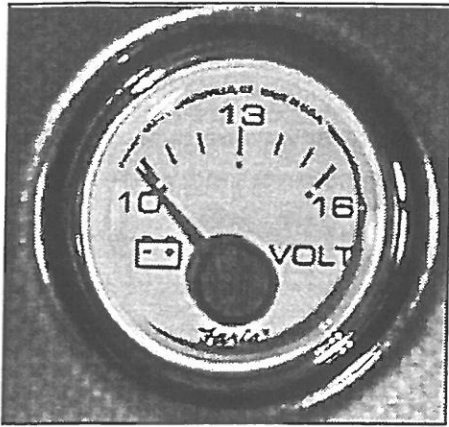

The voltmeter indicates whether the battery is charging or discharging. The needle should be located in the normal range while the engine is running.

If the voltmeter does not register in the normal range, there may be a problem within the electrical system. It is normal for the voltmeter needle to fall when starting the engine. Normal range is 12 to 14 volts.

## OIL PRESSURE GAUGE

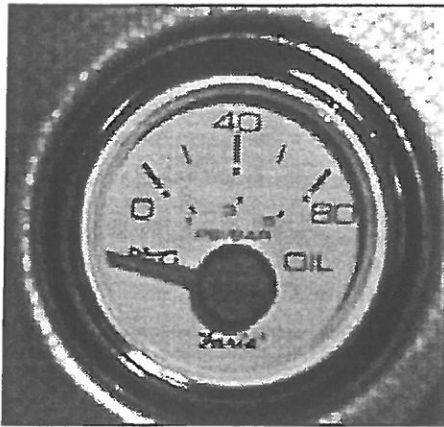

The oil pressure gauge indicates the oil pressure in the engine while the engine is running.

If the oil pressure remains below the normal range of 20 to 40 psi, stop the engine immediately. If engine is allowed to run while oil pressure is too low, permanent engine damage may occur.

## DIPSTICK

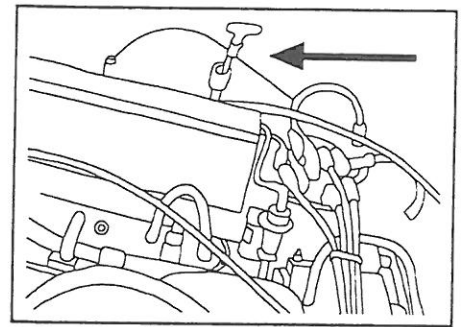

If oil pressure indication is too high or too low (and does not increase) when engine speed is increased, stop the engine immediately and check the level of oil in the engine shown on the dipstick level.

**NOTICE:** The oil pressure varies greatly with engine temperatures and speed.

**NOTICE:** Continued engine operation while oil level is not at a normal level may result in serious engine damage. Please report any problem to your Supra dealer as soon as possible.

## BILGE PUMP SWITCH

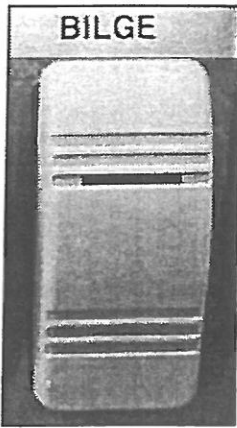

The bilge pump switch operates in two positions. The manual position is used to verify that the pump is operational.

The automatic pump function is engaged at all other times so that any excess water in the bilge may automatically be pumped out.

**NOTICE:** If the Bilge Pump fails to operate in the manual position, press the circuit breaker reset button labeled BILGE. If the bilge pump still does not operate, notify your Supra dealer.

## BLOWER SWITCH

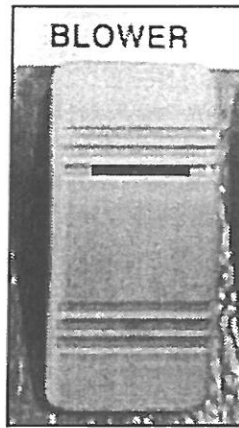

The blower switch activates the blower motor. The primary function of the blower fan is to remove any fumes from the bilge area. The blower also draws fresh air into the engine compartment.

Never depend solely on the blower to eliminate dangerous fumes. Before starting the engine, always open the motor box to check if fumes are present.

Switch on the blower fan a minimum of four minutes before starting the engine.

**NOTICE:** If the blower fails to operate, reset the circuit breaker. If the blower still does not operate, notify your Supra dealer.

## HORN SWITCH

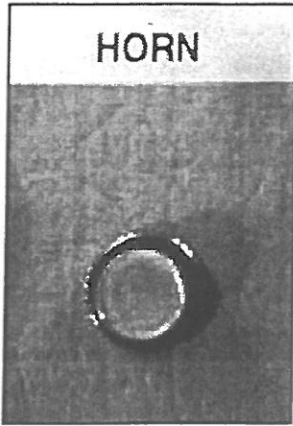

The Horn Switch is located on the port dash panel near the ignition. Sound the horn by depressing the button.

## HORN / WHISTLE SIGNALS

One Long Blast:  
*Warning Signal (Coming out of slip)*  
One Short Blast:  
*Pass on my Port Side*  
Two Short Blasts:  
*Pass on my Starboard Side*  
Three Short Blasts:  
*Engines in Reverse*  
Four or More Blasts:  
*Danger Signal*

1. OVERTAKING / PASSING: Boat being passed has the right-of-way. KEEP CLEAR.
2. MEETING HEAD-ON: Keep to the right.
3. CROSSING: Boat on the right has the right-of-way. Slow down and permit him to pass.

## COURTESY LIGHTS SWITCH

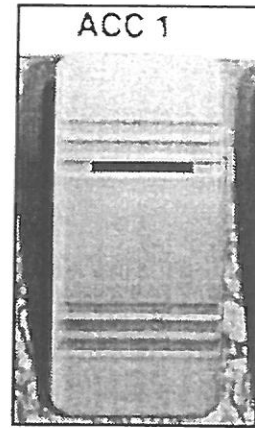

The courtesy lights switch supplies power to the interior lights located to the rear of the helm.

**NOTICE: If lights fail to operate, press the circuit breaker.**

## NAVIGATION LIGHTS

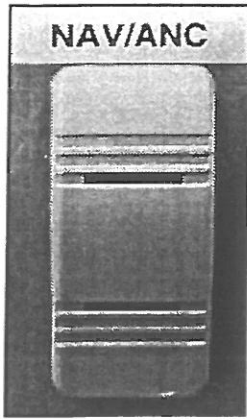

The navigation light switch supplies power to the Bow Light, the Stern Light and the Pole Light.

### OPERATION

When underway during night time operation, set the switch in the NAV position to activate all of the running lights.

When docked or at anchor, set the switch in the ANC position to activate only the pole light.

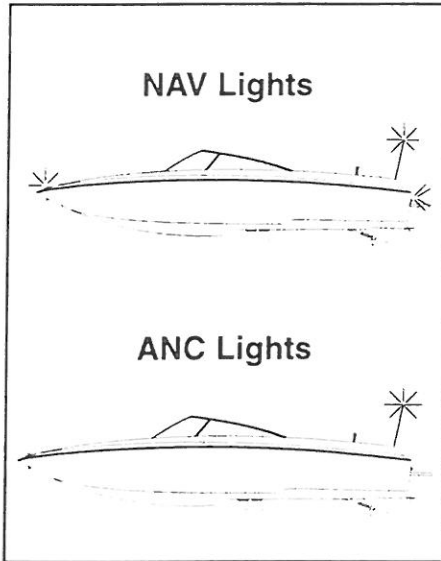

**NOTICE: If lights fail to operate, press the circuit breaker.**

## ACCESSORY SWITCH

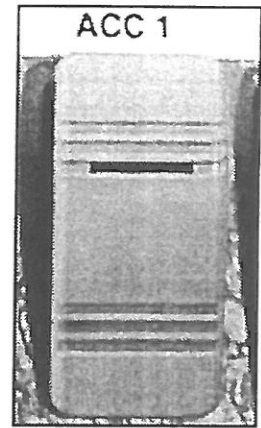

The accessory switch supplies power to an extra circuit for accessories that may be added (such as heaters, hotwater showers, etc.).

**NOTICE: If accessories fail to operate, press the circuit breaker.**

# EQUIPMENT AND OPTIONS

## IGNITION KEYS



Two ignition keys are provided with the boat. Key entry into the ignition may be difficult due to the boot protector. Please do not unduly force the key into the ignition. Key tumblers are located vertically, thus the key should be vertical when placed into the switch.

## GAS KEY

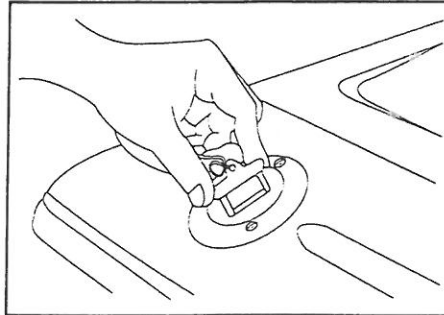

To prevent tampering with fuel system, your Supra is provided with a gas cap, which may be opened only with a key.

**NOTE: The gas cap is sealed by a rubber O-ring. DO NOT over tighten!**

## FLOATING KEY CHAIN

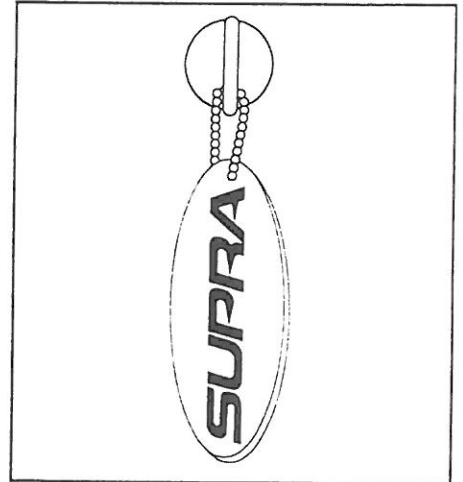

Always attach the ignition key and gas key to a floating key chain to prevent loss in the water.



## DRIVER SEAT

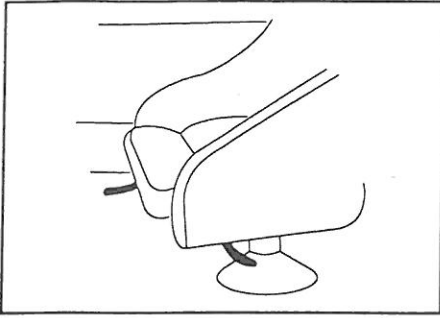

The driver's seat may be adjusted forward or backward by moving the lever below the front of the seat (Lever-A in the drawing). Use body pressure to move the seat to the desired position. Release the lever then check to feel the seat lock into place. The lever on the driver's left side (Lever-B in the drawing) will allow the seat to pivot around for easier access in to and out of the driver seat.

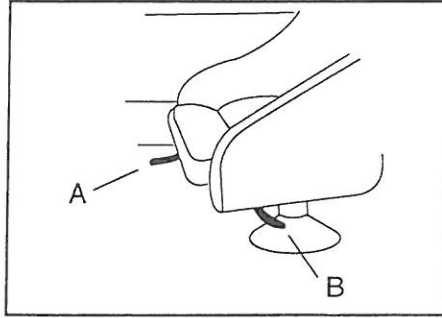

**CAUTION** After adjusting the seat, be sure that it has locked into place by pushing forward and backward until it has securely latched.

**CAUTION** DO NOT attempt to adjust the driver seat while the boat is moving.

## MIRROR

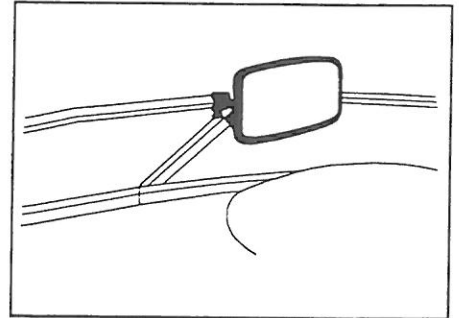

The rear view mirror is installed as a standard item. The mirror is adjustable and is not permanently placed so that it may be set for each driver.

- Mirror should always be checked before driving.
- Mirror angle will change with each new driver.

### SANTERA - SUNSPORT V POLE LIGHT RECEPTACLE

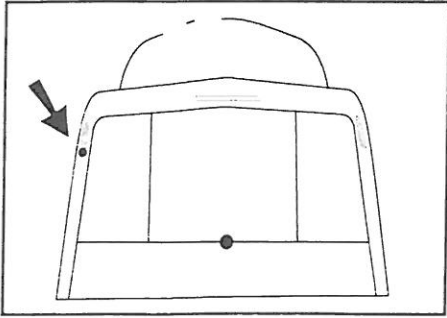

The pole light receptacle is located on the starboard of the stern, along side of the sun deck. To install pole light, slide open the weather cover and insert the pole light in the aligned position.

### SANTERA - SUNSPORT V POLE LIGHT

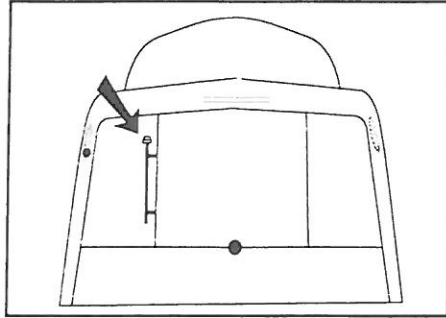

On some models, the removable pole light is stored on the side wall of the rear storage area. Gently pull the pole light from the mounting and place into the pole light receptacle.

The pole light must always be in place and illuminated when visibility is limited. The pole light must be displayed while underway from sunset to sunrise.

### COURTESY LIGHT

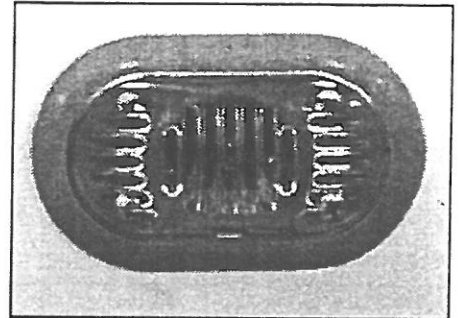

Courtesy lights are installed at several locations in the interior of the boat. The courtesy light switch is located on the instrument panel and is marked "CTS".

## BOW LIGHT

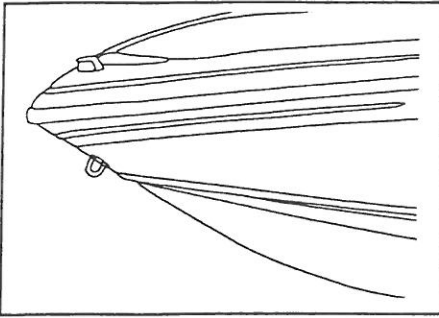

The bow light is located on the bow deck at the front of the boat. To alert other boaters to your position and direction. The light is green on the starboard side and red on the port side.

## STERN LIGHT

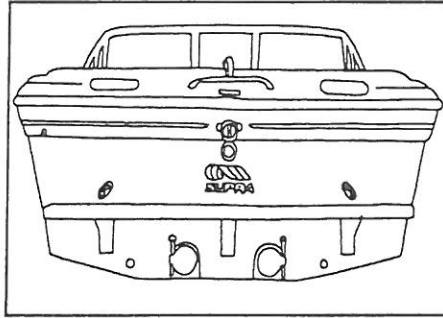

The stern light is located at the center of the transom below the rub rail. This white light alerts other boaters when they are approaching your boat from behind.

## LIFTING RINGS

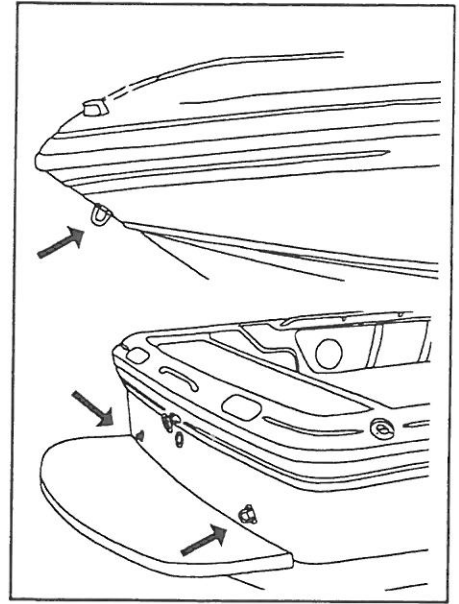

The forward bow eye is located just aft of the bow light. Two lifting rings are located on the transom as illustrated.

**NOTICE:** The lifting rings should be the only means by which the boat is hoisted (See Hoisting Instructions).

## BOW EYE

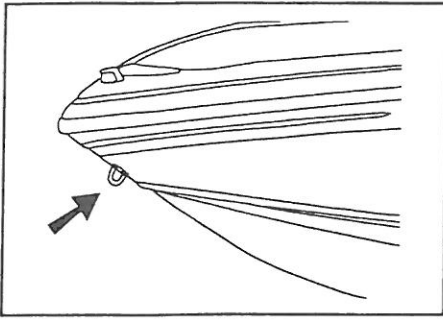

The bow eye is located at the front of the hull below the rub rail. It is the point of the attachment to lead the boat onto the trailer and to secure the boat to the trailer or to tie-off when docking.

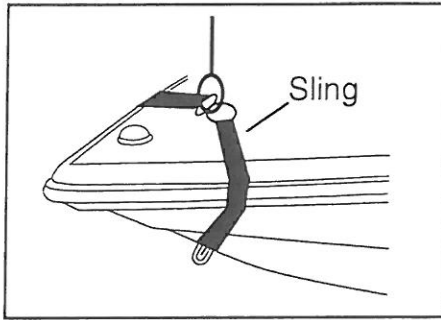

**NOTICE:** Do not use the bow eye **ONLY**, to hoist the boat. You must use a sling with the bow eye when hoisting the boat. Use only the designated lifting rings to hoist the boat. (See Hoisting Instructions)

## BILGE INSPECTION PLATE

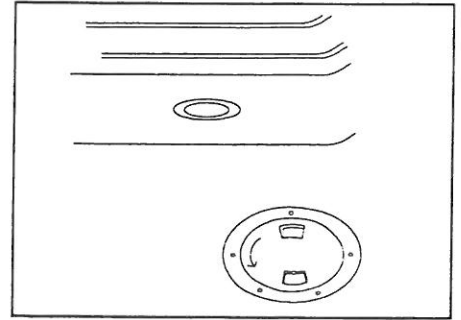

The fuel tank inspection plate is located on the floor. Open the inspection plate by unscrewing it to check the condition of the fuel tank and wire harness.

**NOTICE:** Keep this area clean and free of dirt and debris.

### V-DRIVE BATTERY BOX

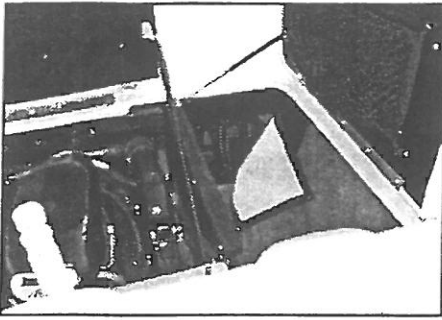

The battery box is mounted inside and to the rear of the port side storage compartment. To access the battery, open the port side storage compartment hatch and pull the cloth handle on the battery access door located in the rear of this compartment.

**NOTICE:** It is recommended that the battery cables be disconnected from the battery when the boat is placed in storage. (Refer to Battery Cable Installation and Precautions)

### INBOARD BATTERY BOX

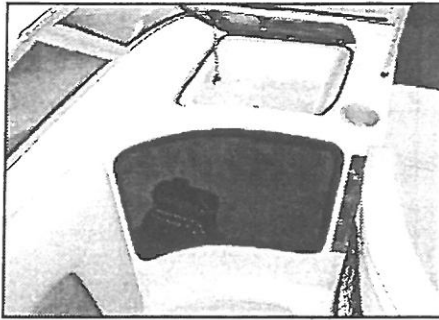

The battery is mounted inside the passenger side storage compartment.

**NOTICE:** It is recommended that the battery cables be disconnected from the battery when the boat is placed in storage. (Refer to Battery Cable Installation and Precautions)

### WALK-THRU WINDSHIELD

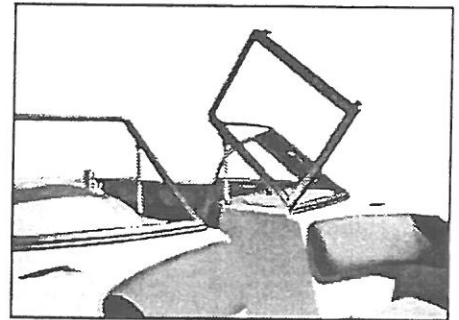

The movable center windshield panel allows access to and from the bow deck. To open, turn safety latches to vertical and push. Lay the center windshield panel gently against the fixed side panel.

## PULLEY & BELT WARNING

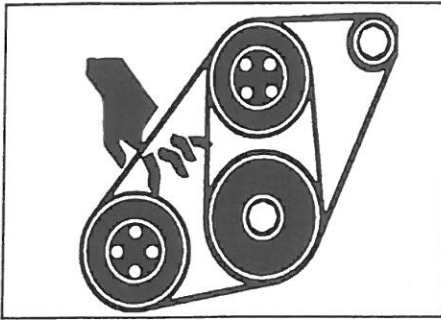

**⚠ WARNING** Pulleys and belts can cause severe injury. Never open motor box while engine is running or while boat is underway.

Remember, after running, the engine is extremely hot and should not be touched or repaired until it has cooled.

## V-DRIVE SKI PYLON

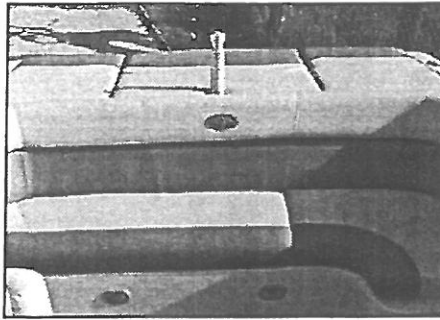

The ski pylon is located in the center portion of the boat directly in front of the motor box. The ski pylon is to be used to pull skiers. **DO NOT use ski pylon to hoist boat.** Only use the lifting rings for this purpose.

**⚠ WARNING** DO NOT mount any Pylon Extension on the rear pylon (located at the rear sundeck).

## INBOARD SKI PYLON

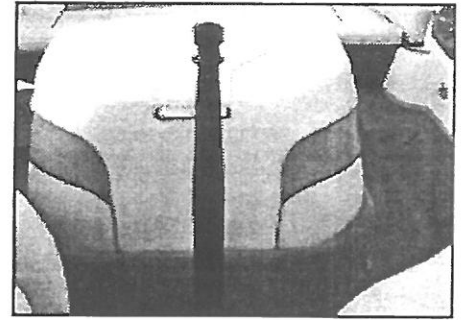

The ski pylon is located in the center portion of the boat directly in front of the motor box. The ski pylon is to be used to pull skiers. **DO NOT use ski pylon to hoist boat.** Only use the lifting rings for this purpose.

**NOTICE:** The use of pylon extensions may cause the pylon to loosen. Please see your dealer for proper tightening procedures.

**⚠ WARNING** The use of pylon extensions can severely effect the overall handling of the boat. Follow pylon extension manufacturers directions for mounting.

## SKI LOCKER

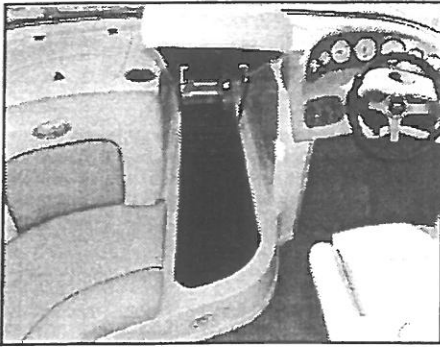

Ski storage is located between the observers seat and drivers console. To open, unsnap strap and lift.

## V-DRIVE ENGINE COMPARTMENT

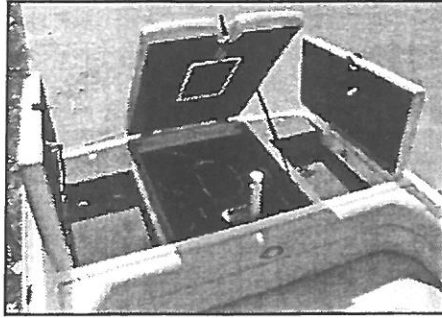

To access the engine, pull the black strap up to trigger the sun deck release.

Note: If the strap is shut inside the engine compartment, you will need to reach through the side storage and manually release the trigger.

When the ski locker is closed, the upholstered lid doubles as a cushioned sun deck.

## SKI PLATFORM

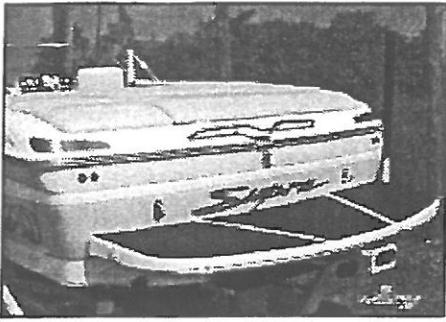

The transom mounted ski platform allows easy access to and from the water for skiers and swimmers.

It is recommended that all entries to and exits from the water be made from the platform to avoid accidents. (The fiberglass deck can become slippery when wet)

**⚠ WARNING** Shut off the engine when people are on the platform or in the water near the platform.

## DETACHABLE BRACKET

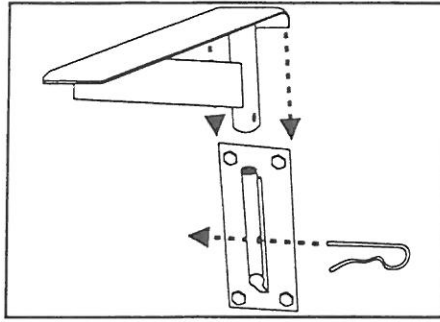

The ski platform is attached to the boat with detachable brackets. The platform may be removed from the boat by pulling the retaining pins from the brackets and lifting up and out.

## PROPELLER

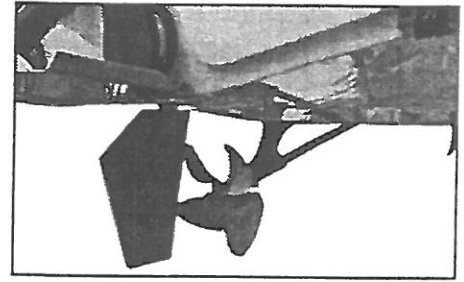

The design team at Supra has carefully explored and tested many different propellers and pitch angles for use on our boats. All tests indicate that the current propeller installed on the boat is the best suited for the variety of boating performance required, whether skiing competitively or cruising just for pleasure.

It is highly recommended that the Supra dealer be notified before changing the propeller. In general, changing the factory installed propeller to a lower pitched propeller will increase acceleration, but will decrease top speed. Changing the factory propeller to a higher pitched propeller may achieve higher top speed with a light load, while acceleration and power may decrease.



## PROPELLER PRECAUTION

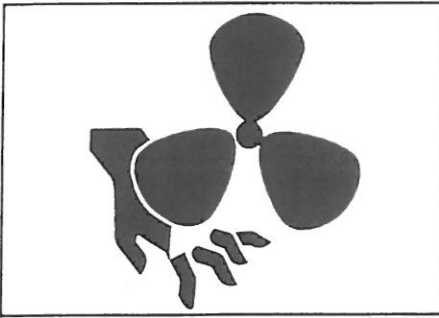

**⚠ WARNING** A moving propeller will cause injury. The propeller may turn with the boat in neutral. Shut off the engine while skiers or swimmers are in the water near the ski platform.

**NOTICE:** Under no circumstances should a propeller be used, which allows the engine to exceed manufacturer's recommended RPM's be installed on the boat.

## SPEEDOMETER PADDLE WHEEL

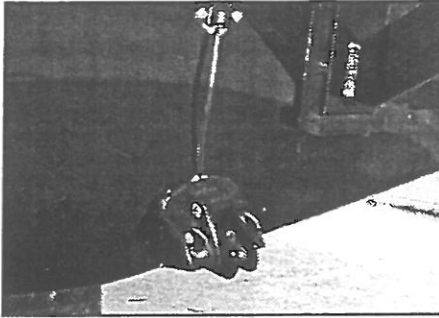

The Speedo Pick-up is a paddle wheel located at the back of the boat. Poor water conditions may cause the wheel to become clogged or give incorrect information.

## STEREO

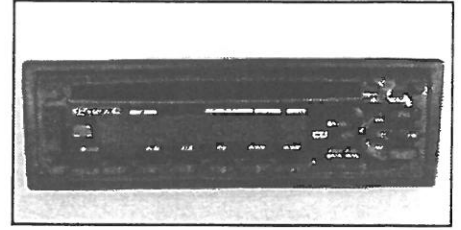

The stereo is located in the glove box. A remote is located on the dash, however, the stereo must be turned off at the stereo not the remote.

**NOTE:** The face plate should be black in the off position. If the face plate says off, it is in standby mode and still drawing voltage.

## DEPTH FINDER

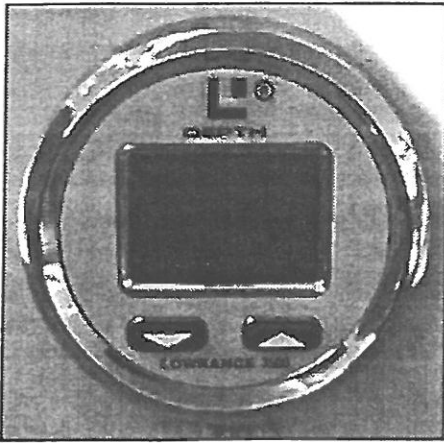

Please refer to depth finder packet for operation instructions.

## BALLAST



To fill the ballast system press the fill switch. To empty, press the empty switch. With the ballast full the boat porpoise at speeds above 25 mph.

**⚠ WARNING DO NOT tow boat on trailer with ballast full.**

## TILT STEERING

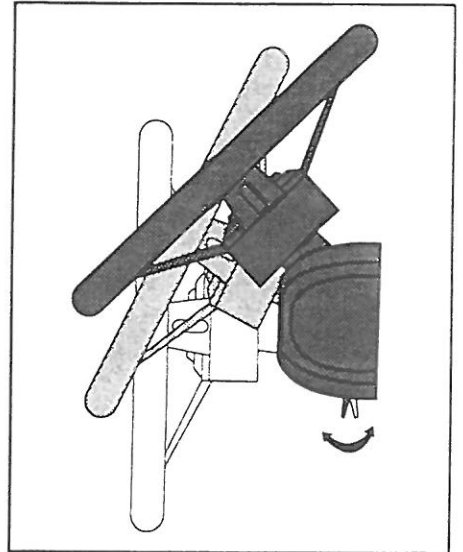

The tilt steering may be adjusted up or down in five different locking positions. To adjust, depress the tilt lever located beneath the bezel and move the steering wheel to the desired position. Release the lever and the tilt steering will lock into place.

## V-DRIVE FUEL TANK

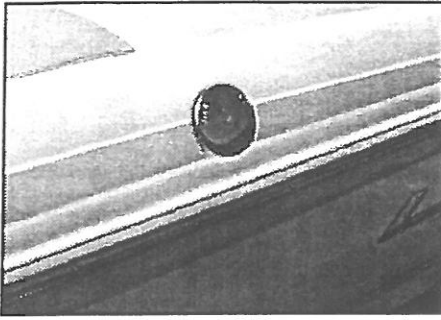

The fuel cap is located in the middle of the rear of the boat. A specially designed fuel key is provided to open the cap.

**NOTE:** The cap is sealed by a rubber O-ring. Please do not over tighten.

## FILLING THE FUEL TANK

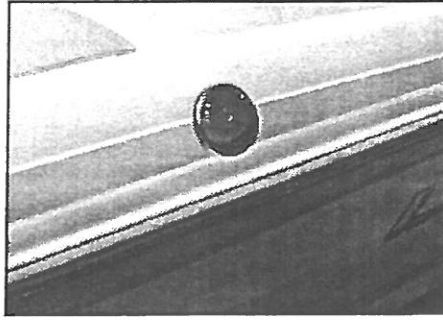

**NOTICE:** Pay careful attention when filling the fuel tank. **DO NOT overfill the tank!** Fuel may empty through the fuel vent and damage to the outside finish could result.

If fuel is spilled on stripes or decals, apply a common bath cleaner and wipe with a damp cloth. Rinse spill area with clean water.

## FUEL PRECAUTIONS

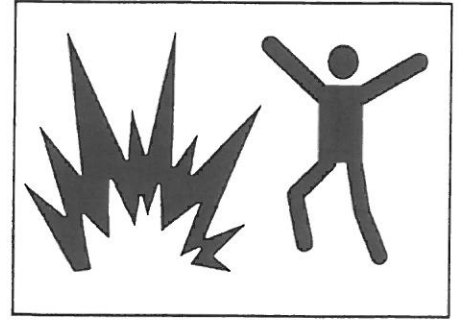

**⚠ WARNING** Sparks while fueling could cause an explosion!

### BEFORE FUELING:

1. Turn off engine.
2. Turn off all electrical systems.
3. Extinguish cigarettes or any open flame.

### WHILE FUELING:

1. Keep fuel hose nozzle in contact with fill pipe to provide grounding.
2. Fill tank at a slow rate to avoid spills.

## COOLER

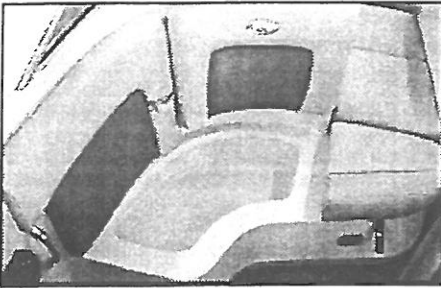

The built in cooler is located under the observer's seat cushion.

## TRIM SWITCH AND GAUGE

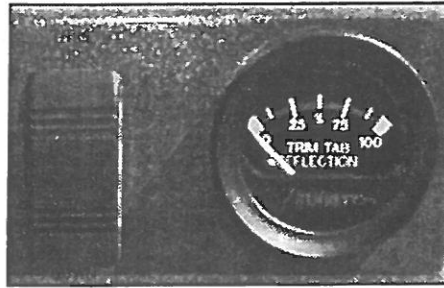

This switch controls the optional hydraulic plate. The gauge indicates the position of the plate. The gauge will only read from 0° to 50° due to restricter in the ram.

## WAKEPLATE HYDRALIC

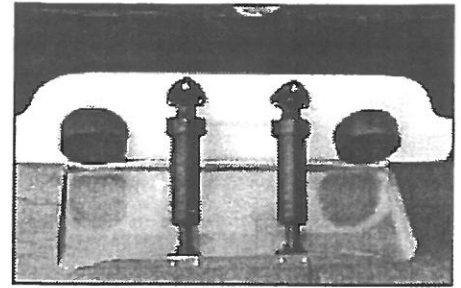

The optional hydraulic wake plate allows the driver to control the running attitude of the boat.

## POP-UP CLEAT

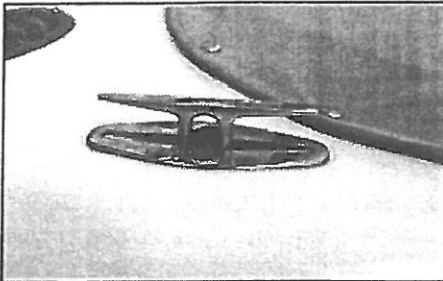

To use cleat pull center up.

**⚠ WARNING** DO NOT tow objects with cleats.

## FUEL VENT

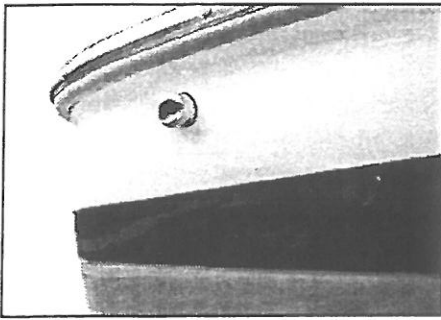

The fuel vent is located on the back corner of the boat. This vent is connected to the fuel tank via the vent hose, which releases gasoline fumes from the fuel tank.

**⚠ CAUTION** Gasoline vapors are highly explosive.

## FIRE EXTINGUISHER

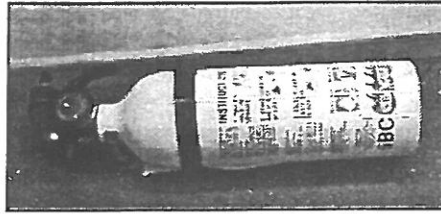

A standard United States Coast Guard approved fire extinguisher is provided with your Supra boat. The fire extinguisher is located under the observers seat on the port side of the boat. Simple pull up the cushion to expose the fire extinguisher.

**NOTICE:** Refer to the instructions on the fire extinguisher for proper use.

## FLAME PRECAUTIONS

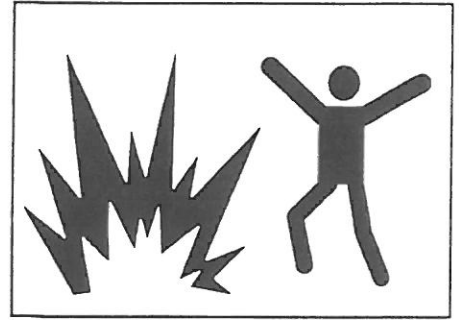

**⚠ WARNING** Sparks while fueling can cause explosion! Extreme caution should be taken when an open flame is present on board. Fumes from the engine and fumes from the battery are highly flammable. No flame or spark should come near these areas.

# SERVICE & MAINTENANCE

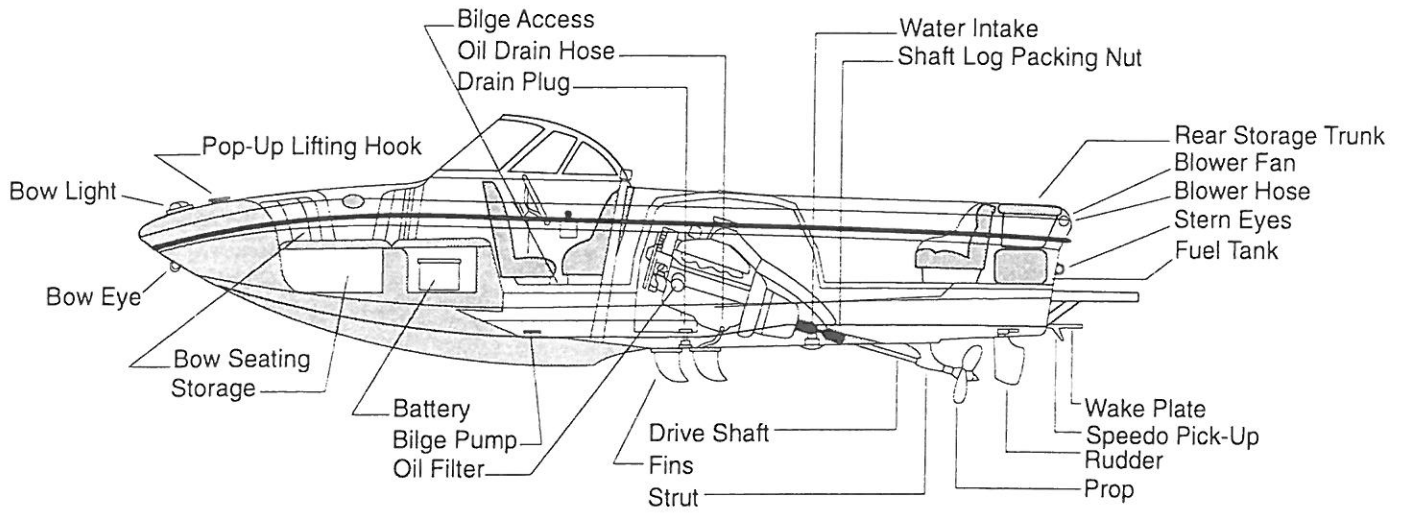

The illustration above denotes the areas which may need to be accessed or may require cleaning or maintenance. It is important to have basic understanding of the parts and their location on the boat. However, it is recommend that any service beyond routine maintenance be performed by an authorized Supra dealer.

## SERVICE & MAINTENANCE

For your convenience, a maintenance schedule has been included in this manual. The items listed outline when to perform safety checks, lubrication and general service to your boat. Engine hours or elapsed time determine when service is necessary.

It is recommended that any replacement parts used during maintenance or for repair be supplied by an authorized Supra dealer.

**NOTICE:** You are responsible for keeping records of all maintenance on your boat. To maintain your new boat warranty, you may be required to prove that required maintenance was performed.

## ENGINE OIL & FILTER

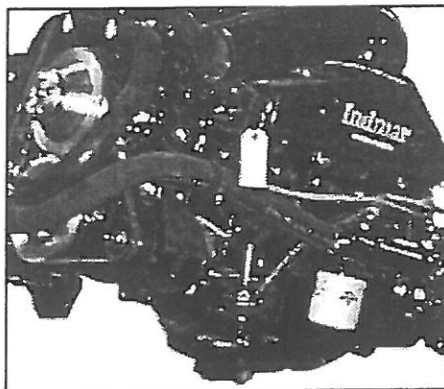

Crankcase oil should be selected to deliver the highest performance for your operating conditions and climate. In general, engine oils with lower viscosity ratings are used when temperatures remain low or when better fuel economy is desired. Oils with higher viscosity ratings are used when temperatures remain higher and when higher performance is expected from the engine.

The Engine Manufacturer recommends Pennzoil 15W-40 Marine Motor Oil. If this is unavailable, a high grade 20W50 with an A.P.I. classification of SH, SJ, SG/CD is acceptable.

## OIL DRAIN

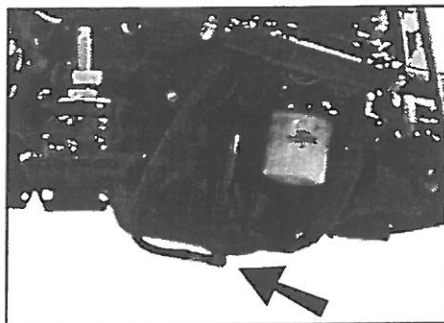

**REFER TO ENGINE MANUAL**

# MAINTENANCE CHART

Maintenance Intervals (@ Engine Hours)

	Weekly	25 hr	50 hr	100 hr	Annual
Change Engine Oil		✓	✓	✓	✓
Replace Oil Filter		✓	✓	✓	✓
Check Transmission Fluid Level	✓	✓	✓	✓	✓
Check V-Drive Fluid Level	✓	✓	✓	✓	✓
Change V-Drive & Transmission Fluid					✓
Check Sea Water Strainer	✓ <sup>1</sup>	✓ <sup>1</sup>	✓ <sup>1</sup>	✓ <sup>1</sup>	✓
Clean Flame Arrestor		✓		✓	✓
Clean Crankcase Ventilation System		✓			✓
Check Water Pump & Alternator Belt Tension	✓	✓			✓
Change Fuel Filter					✓
Check Fuel Line Connections for Leaks	✓	✓	✓	✓	✓
Clean Carburetor Fuel Inlet Filter		✓	✓	✓	✓
Check Condition of Spark Plug					✓
Check All Electrical Connections		✓			✓
Check Cooling System Hoses for Leaks	✓	✓			✓
Tighten Engine Mount Fasteners		✓		✓	✓
Lubricate Throttle & Shift Linkage Pivot Points					✓
Check for Loose, Damaged or Missing Parts	✓	✓			✓
Check Engine to Propeller Shaft Alignment		✓			✓
Lubricate Rudder Port				✓	✓
Check Shaft Log		✓		✓	✓

<sup>1</sup> If engine overheats, visually check. If clogged, remove debris.

This inspection and maintenance schedule is recommended for average operating conditions in normal service. Under severe operating conditions or service, intervals should be shortened.



## OIL LEVEL CHECK

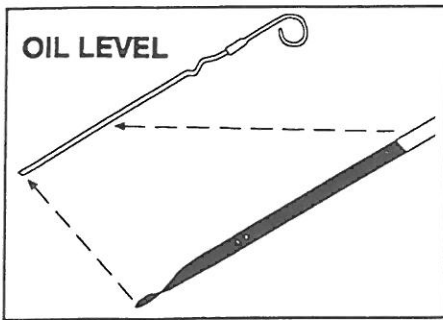

Engine oil level should be checked at regular intervals (such as every 5 engine hours). To obtain a true reading, when the engine is at operating temperature and turned off, check the oil level showing on the dipstick.

If the oil level is between the "FULL" and the "ADD" marks on the dipstick, simply replace the dipstick. When the oil level is at or below the "ADD" mark, add oil to return the level to the "FULL" mark.

## TRANSMISSION

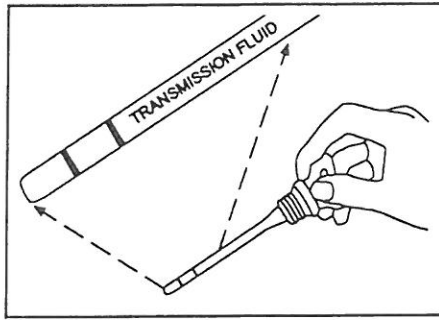

Use only automatic transmission fluid type "A" in transmissions with 1:1 drive train. Refer to Engine Owners Manual.

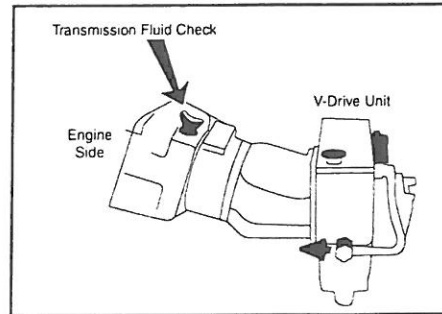

## CHANGE FREQUENCY

Change transmission fluid every year, using only Dextron-III Mercon automatic transmission fluid.

## MAINTAINING FLUID LEVEL

Transmission fluid level should be checked regularly (refer to page 46) and fluid added if necessary. Maintain fluid levels as follows:

- Boat must be at rest.
- Engine should be at operating temperature, but turned off while checking level.
- Remove transmission fluid dipstick.
- Wipe fluid clean from dipstick and replace.
- Remove dipstick and note level indicated by the upper and lower marks.
- If required, add fluid to bring the level to the upper mark.

## V-DRIVE LOCATION

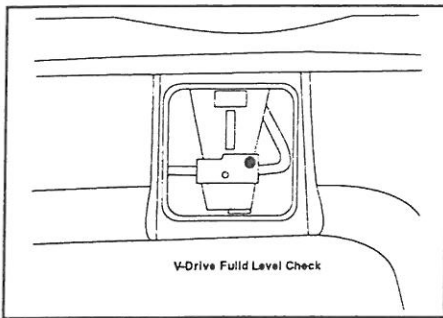

The fluid level can be checked by using the oil level gage, which is located on top of the V-Drive transmission. This unit is located under the center cushion of the rear seat. Pull out the cushion to access the transmission.

## V-DRIVE FLUID CHECK

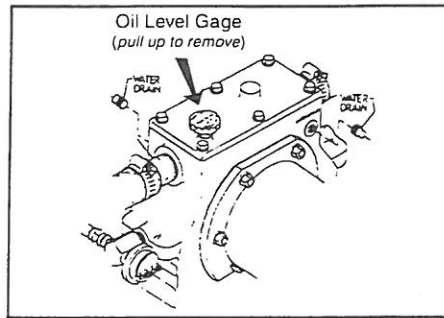

Pull the oil level gage to check the fluid level. If the level is low, add fluid to the correct mark on the dip stick. Use SAE 30 motor oil.

**NOTE:** Only a trained & qualified technician should perform the oil change on your V-drive unit.

## CHANGE FREQUENCY

The oil should be changed in the V-Drive transmission after the first 100hrs of operation, than each year at the end of your boating season.

## MAINTAINING FLUID LEVEL

Transmission fluid level should be checked regularly (refer to page 46) and fluid added if necessary. Maintain fluid levels as follows:

- Boat must be at rest.
- Engine should be at operating temperature, but turned off while checking level.
- Remove transmission fluid dipstick.
- Wipe fluid clean from dipstick and replace.
- Remove dipstick and note level indicated by the upper and lower marks.
- If required, add fluid to bring the level to the upper mark.

## COOLING SYSTEMS

### FRESH WATER COOLING SYSTEM

The standard cooling system for Supra boats is an open circulation cooling system with intake water. This is preferred for lakes and reservoirs with low salt content. If the engine is occasionally operated in salt water, the cooling system should be flushed with fresh water periodically and always before storage. If your boat is regularly operated in salt water, it should be equipped with the optional salt water package.

### SALT WATER COOLING SYSTEM

The optional cooling system for use on salt water is a closed system with a solution of 50% antifreeze and 50% fresh water. The coolant is left in the closed system and replaced once a year.

## BODY LUBRICATION

Normal use of your Supra causes metal to metal movement at some parts in the boat. Driver seat track should be lubricated with a water resistant chassis lubricant such as silicon grease.

Lubricate rudder grease fitting located below the engine, once annually.

## SHAFT LOG PACKING NUT

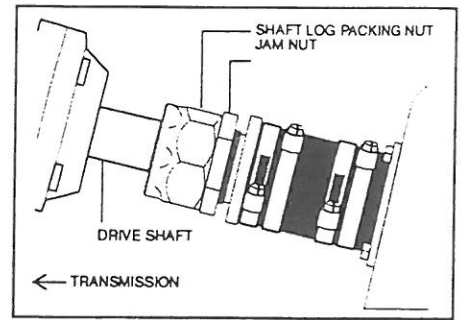

The Shaft Log Packing Nut should be checked periodically and adjusted if needed. Adjust as follows: Loosen the jam nut a few turns. Tighten the shaft log packing nut by hand. **DO NOT** over tighten. Tighten the jam nut against the packing nut. Check for leaks.

**NOTICE:** It is normal for the Packing Log to drip water at a slow rate of one drop every 15 to 30 seconds.

## BATTERY CABLE INSTALLATION AND PRECAUTIONS

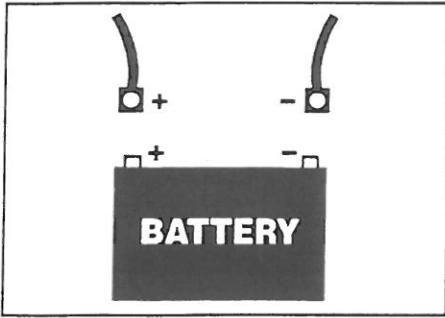

Your Supra electrical system is a negative ground type. The negative battery cable is grounded to the engine block. The positive battery cable is connected to the starter solenoid. Connect the positive (+) battery cable to the positive (+) post on the battery. Connect the negative (-) battery cable to the negative (-) post on the battery.

**⚠ CAUTION** Failure to connect battery cables as outlined will damage the system and void the warranty.

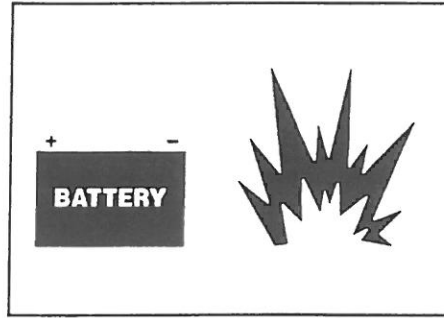

**⚠ WARNING** Hydrogen and oxygen gases are produced during normal battery operation and charging. Sparks or flames near the battery vent openings can cause the mixture to ignite and explode.

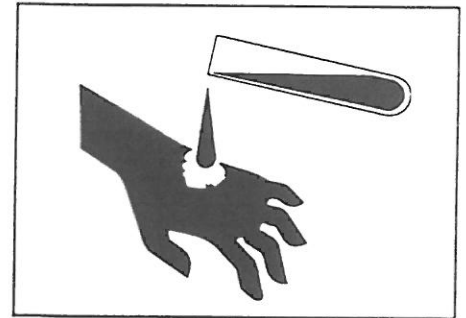

**⚠ WARNING** Sulfuric acid in the battery can cause serious burns. If spilled on skin or in eyes, flush with clean water immediately, then seek medical attention.

## V-DRIVE DRAIN PLUG

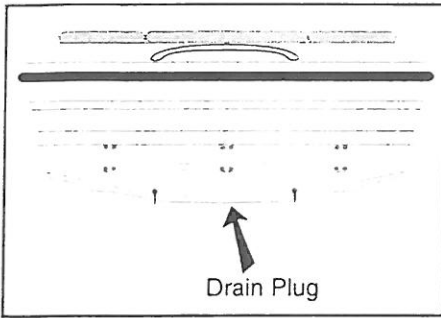

The bilge area drain plug is located at the back of the boat, near the bottom of the transom. It is extremely important that the drain plug is always checked before starting the engine. The drain plug should be secured in place using a wrench.

**⚠ CAUTION** DO NOT start the engine until the drain plug is checked and secured in place.

DO NOT try to install the drain plug while the engine is running.

## SUNSPORT DRAIN PLUG

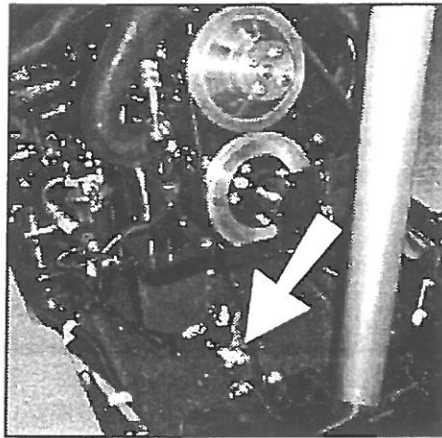

The T-handle drain plug is located in the center of the boat. It is accessible by opening the motor box.

**⚠ CAUTION** DO NOT start the engine until the drain plug is checked and secured in place.

DO NOT try to install the drain plug while the engine is running.

## FUEL FILTER

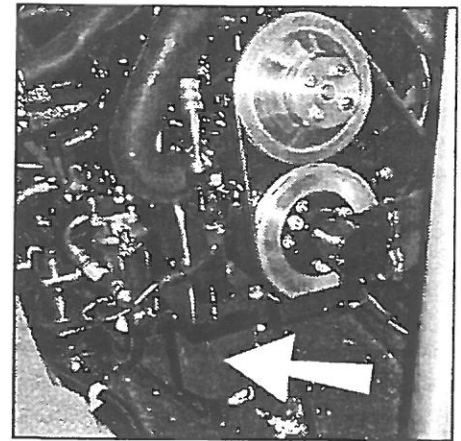

The fuel filter is mounted on top of the engine on the port side of the intake manifold. It should be replaced annually. There is also a water separator located on the front of the engine (near the transom on the port side) and it should also be checked annually.

## WASHING

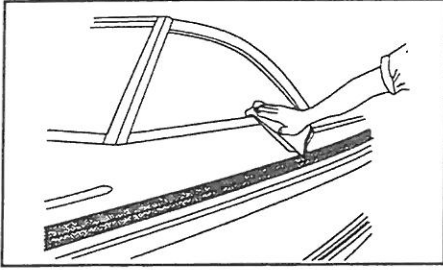

The easiest way to preserve the beauty of your boat is to keep it clean by frequent washing. Wash the boat with luke warm or cold water. Wipe the boat down immediately after washing to avoid water spots. Avoid using hot water or washing your boat in direct sunlight. Avoid using strong soaps or chemical detergents. To avoid spotting, all cleaning agents should be thoroughly rinsed from the surface promptly and not allowed to dry on the finish.

## RUB RAIL CARE

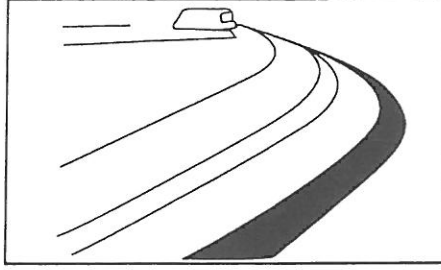

Use a sponge or other soft material to wash and wax the rubber rub rail. To wax, use a commercial automotive black bumper wax.

**NOTICE: When tying up to a dock or another boat, always use cushioned fenders (dock bumpers) to protect your boat from hard surfaces.**

## WINDSHIELD CARE

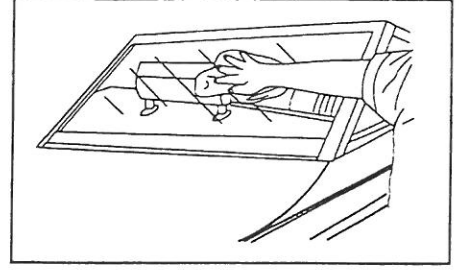

All Supra windshields are constructed of tempered safety glass to insure passenger safety. The glass surfaces should be cleaned regularly to insure that visibility is not obstructed.

Use a commercial glass cleaner to remove any spotting or stubborn stains that develop on the windshield. Never use abrasive cleaners on glass surfaces.

## FIBERGLASS CARE

Washing and waxing the boat hull and deck regularly will extend the life and beauty of your Supra. It is a good routine to rinse your boat with fresh water after each day's use.

It is recommended that the hull and deck be cleaned and waxed after every 25 hours of use. This will decrease water friction and lessen the potential for staining or spotting on the gelcoat surface.

When the original gelcoat shine cannot be restored by waxing, the shine may be restored by hand buffing with a commercial polishing compound. Be sure to apply a new coat of wax containing Carnauba over the area that has been polished.

**IMPORTANT: Porcelain cleaning powders are too abrasive for use on gelcoat and may cause permanent discoloration if used. Household detergents containing ammonia or chlorine should not be used on gelcoat. Never use acetone or ketone solvents to clean your boat finish.**

## FOREIGN DEPOSITS

Tree sap, bird droppings, air borne chemicals, petroleum products and other foreign matter may damage the gelcoat surface if not removed promptly (SEE WASHING INSTRUCTIONS).

## BOAT HULL PROTECTION

If your Supra is to remain in salt water for an extended period, the hull below the water line should be painted with a marine bottom paint. Bottom paint is also recommended for fresh water locations where the boat is left in the water for extended periods of time.

## TEAK WOOD CARE

If teak wood has been installed on your Supra, a small amount of maintenance will be required to retain the natural beauty. Teak wood should not be varnished. Instead, teak oil or mineral oil should be applied. Oil should be applied 3 to 4 times per year. If teak has been allowed to become gray and dry, sand with fine grit paper and reapply teak oil.

## UPHOLSTERY CARE

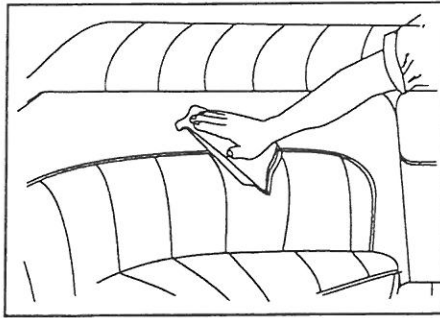

All upholstery items on your Supra are made of tough marine grade vinyl that is easily cleaned.

**⚠ CAUTION** Strong detergents and cleaners may shorten the life of the vinyl. PLEASE SEE VINYL MANUFACTURER'S RECOMMENDED CARE GUIDE INCLUDED IN YOUR OWNER'S MANUAL PACKAGE.

**FAILURE TO FOLLOW CARE GUIDE MAY VOID VINYL WARRANTY.**

## DRYING UPHOLSTERY

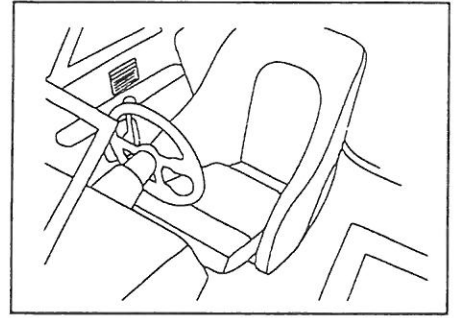

It is important to provide for the drying of all upholstery and carpet after each use of the boat. Open all storage compartments and slide all removable cushions out about an inch to allow air to circulate behind.

## IDENTIFICATION NUMBER

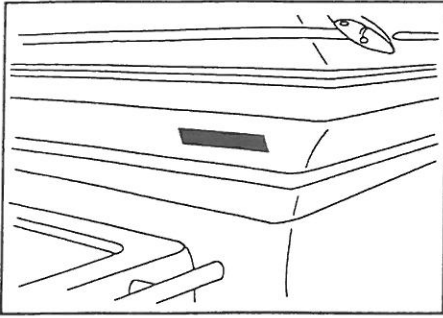

The hull identification number is located on the upper right hand side of the transom below the rub rail.

The following describes the identification number in detail.

ISRS 0000 K 0 01

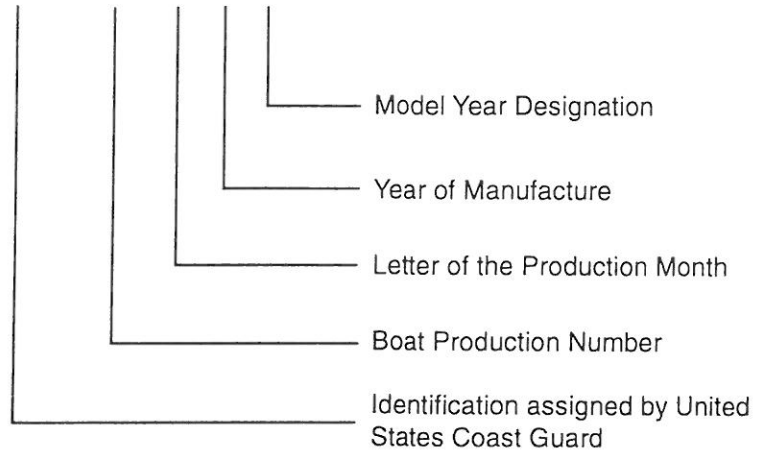



# TECHNICAL INFORMATION

## ENGINE & TRANSMISSION DATA

### Engine Model: ..... Indmar Assault MPI

Fuel Delivery: ..... Multi Port Fuel Injection  
 Horsepower: ..... 330-hp  
 Displacement: ..... 350-ci  
 Bore (in): ..... 4.00  
 Stroke (in): ..... 3.48  
 Compression Ratio: ..... 9.4 to 1  
 Electrical System: ..... 12-V Neg Ground  
 Ignition Type: ..... Electronic Distributor  
 Alternator Output: ..... 51 Amps @2,200 RPM  
 Thermostat: ..... 143 Degrees F  
 Firing Order: ..... 1-8-4-3-6-5-7-2  
 Initial Timing: ..... 10 Degrees / Service Mode  
 Oil Filter: ..... Pennzoil PZ-3  
 Oil Capacity: ..... 5-Quarts  
 Oil Type: ..... Pennzoil 15W-40 Marine  
 Transmission Fluid: ..... Dextron III-Mercon  
 Spark Plugs: ..... AC MR43LTS  
 Gap: ..... 0.045  
 Max RPM's: ..... 5,200 RPM

### Engine Model: ..... Indmar Assault TBI

Fuel Delivery: ..... Throttle Body Fuel Injection  
 Horsepower: ..... 320-hp  
 Displacement: ..... 350-ci  
 Bore (in): ..... 4.00  
 Stroke (in): ..... 3.48  
 Compression Ratio: ..... 9.4 to 1  
 Electrical System: ..... 12-V Neg Ground  
 Ignition Type: ..... Electronic Distributor  
 Alternator Output: ..... 51 Amps @2,200 RPM  
 Thermostat: ..... 143 Degrees F  
 Firing Order: ..... 1-8-4-3-6-5-7-2  
 Initial Timing: ..... 10 Degrees / Service Mode  
 Oil Filter: ..... Pennzoil PZ-3  
 Oil Capacity: ..... 5-Quarts  
 Oil Type: ..... Pennzoil 15W-40 Marine  
 Transmission Fluid: ..... Dextron III-Mercon  
 Spark Plugs: ..... AC MR43LTS  
 Gap: ..... 0.045  
 Max RPM's: ..... 4,850 RPM

### V-Drive: ..... Walters

Model: ..... RV-26 D  
 Ratio: ..... 1.46 to 1  
 Oil Type: ..... SAE-30  
 Oil Capacity ..... 2 pints

## BATTERY SPECIFICATIONS

12 Volt Marine Type with Tapered Post Connectors

Engine Size:	Cold Crank @ 0° F (-18° C)
350	650 Amps

**⚠ WARNING** Hydrogen and oxygen gases are produced during normal battery operations or charging. Sparks or flames can cause this mixture to ignite and explode if it comes near the vent openings. Sulfuric acid in the battery can cause serious burns, if spilled on skin or in eyes. Flush with clear water immediately.

### **SUPRA WARRANTY**

Supra is proud of our products and to show that we mean it, we back each boat with a lifetime warranty on the Supra Comp and Legacy models. This dedication proves that we only use the finest quality materials and meticulously manufacture every Supra product to insure that each customer receives the finest product on the market!

### **SUPRA LIFETIME LIMITED WARRANTY**

There are no expressed or implied warranties on products manufactured or sold by Skier's Choice except as set forth in this Limited Warranty Agreement. Except as excluded or limited in this Warranty, Skier's Choice, Inc., 5820 US 411 South, Maryville, TN 37801 warrants to the first owner that this new Supra Comp or Legacy boat is free from defects in materials and workmanship, under normal use and when operated and maintained accordingly to instructions for the term set forth as follows:

For a period of twelve (12) months from the date of purchase on all covered components other than the deck, hull, flooring (excluding carpet) and stringers.

For the lifetime of the product on the deck, hull, flooring (excluding carpet) and stringers.

### **SKIER'S CHOICE OBLIGATIONS:**

Skier's Choice, Inc. will repair or replace, at its sole option, any part covered under this Warranty, which is returned by the owner during the warranty period to Skier's Choice, Inc. factory or to any other Supra authorized repair facility and which, upon Skier's Choice, Inc's examination, discloses to Skier's Choice, Inc's satisfaction a defect at the time of delivery to the first owner. In case of such defects, Skier's Choice, Inc. will fulfill its obligation to repair or replace the defective item within (90) days of receipt of the defective part at its factory or any Supra authorized repair facility. Replacements will be warranted only for the remainder of the original warranty period. The repair or replacement of defective parts under warranty will be made by Skier's Choice, Inc. without charge to the owner for parts or labor.

Transportation of the boat or parts to the authorized Supra facility shall be borne by the owner and return transportation charges shall be prepaid by the owner. The replacement or repair of the defective parts as stated in this Warranty shall be the sole remedy of the Purchaser and the sole liability of the Dealer and the Company under the Warranty and any implied warranties.

### **SUPRA EXCLUSIONS**

The following are specifically excluded from coverage under this warranty:

Anyone other than the first owner.

Paints, varnishes, gelcoat surfaces and colors, finish distortions, chrome plated or anodized finishes, floor coverings and any other surface coatings.

All component parts and accessories not manufactured by Skier's Choice, Inc., including but not limited to, engines, gear trains, drive trains, transmissions, propellers, shift and throttle control levers and cables, bilge pumps, other pumps, blowers, windshields, canvas, upholstery, batteries, instrumentation and steering systems. However, where any such items are warranted by a component or accessory manufacturer, Skier's Choice, Inc. will, if possible, furnish the warranty document to the owner. Subsequent damage from bilge pump failure or other component part failure will not be the responsibility of Skier's Choice, Inc.

Any equipment installed by a Dealer or any other installer.

Any boat which is: (a) used for rental or other commercial, military or industrial purposes; (b) used in boat racing, demonstrations or similar events; (c) altered, modified, repaired or replaced so as to increase the cubic inch capacity or horsepower output of the engine and boat as originally manufactured.

Speeds, fuel consumption and other performance characteristics because they are estimated and may vary.

Any damage or repair required because of misuse, negligence, accident, collision or impact with any object; or any improper alteration or repair.

Any boat used for speed, competition or performance demonstration.

The Lifetime Warranty on the deck, hull, flooring and stringers does not include hardware or other components fastened or adhered to the hull, deck, flooring or stringers.

If you must leave your boat in the water for long periods of time, a condition may develop wherein the hull may show signs of discoloration. This discoloration will not be covered for warranty by Skier's Choice, Inc., nor our raw materials supplier.

Skier's Choice, Inc. reserves the right to improve its products through changes in design or material without being obligated to incorporate such changes in products of prior manufacture.

**OTHER LIMITATIONS**

THIS WARRANTY LIMITS THE DURATION OF ANY IMPLIED WARRANTY OF MERCHANTABILITY OR IMPLIED WARRANTY OF FITNESS FOR A PARTICULAR PURPOSE TO THE PERIOD OF TWELVE (12) MONTHS

(LIFETIME ON THE DECK, HULL, FLOORING AND STRINGERS) FROM THE DATE OF PURCHASE. Some states do not allow limitations on how long an Implied Warranty lasts, so this limitation may not apply to you.

THE REMEDIES OF REPAIR OR REPLACEMENT AT OUR OPTION, AS SET FORTH ABOVE, ARE THE ONLY REMEDIES UNDER THIS WARRANTY. UNITED MARINE CORP. DISCLAIMS ANY OBLIGATION OR LIABILITIES FOR LOSS OF USE OF PRODUCT WARRANTED, LOSS OF TIME, INCONVENIENCE, COMMERCIAL LOSS OR ANY OTHER DIRECT, CONSEQUENTIAL, SPECIAL OR INCIDENTAL DAMAGES. Some states do not allow the exclusion or limitation of incidental or consequential damages, so the above limitations or exclusions may not apply to you.

THIS WARRANTY IS IN PLACE OF ANY OTHER EXPRESS WARRANTIES.

THIS WARRANTY APPLIES TO THE FIRST OWNER ONLY AND IS TRANSFERABLE ONLY IN THE FIRST TWO (2) YEARS.

THIS WARRANTY GIVES YOU SPECIFIC LEGAL RIGHTS, AND YOU MAY ALSO HAVE OTHER RIGHTS WHICH VARY FROM STATE TO STATE.

THIS WARRANTY IS EXPRESSLY IN LIEU OF ANY CONTRACTUAL LIABILITIES, INCLUDING PRODUCT LIABILITIES.

THE DEALER IS NOT THE AGENT OF SKIER'S CHOICE, INC. THE COMPANY DOES NOT AUTHORIZE THE DEALER, OR ANY OTHER PERSON, TO ASSUME FOR THE COMPANY, ANY LIABILITY OR EXPENSE INCURRED IN THE REPAIRING OF ITS PRODUCTS OTHER THAN THOSE EXPRESSLY AUTHORIZED IN THIS LIMITED WARRANTY. THE DEALER MAY NOT EXTEND OR IN ANY WAY CHANGE OR AMEND THIS EXPRESS WARRANTY.

## OWNER'S RESPONSIBILITY

1. Before operating your Supra, it is necessary to read and fully understand this Owner's Manual and all other information delivered with the boat.
2. It is the owner's responsibility to take the boat to an authorized Supra dealer to obtain warranty service.
3. It is the owner's responsibility to properly operate and maintain the boat in accordance with this manual and all other information delivered with the boat.
4. The owner should keep maintenance records should it be necessary to show that required maintenance has been performed on the boat.

## DEALER'S RESPONSIBILITY

1. The Dealer should provide the buyer with an adequate orientation in the general operation of the boat and review all systems and accessories included with the boat.
2. The Dealer should deliver a complete owner's manual packet with the boat consisting of Owner's Manual, Registration Engine Manual, Stereo Manual, Supra Warranty and all warranties for separately warranted items aboard the boat.
3. The Dealer should review all warranty information with the buyer and assist in filling out warranty cards if necessary.
4. The Dealer should insure that any information or obligation from either Skier's Choice, Inc. or from the dealership is clearly understood by the buyer.
5. The Dealer should instruct the buyer in obtaining local service and out-of-area service for a Supra boat.

## CUSTOMER ASSISTANCE

The staff at Skier's Choice, Inc. is concerned with your complete satisfaction. This includes the prompt resolution of any problems that may arise during the warranty period. Normally, problems encountered may be efficiently and effectively resolved by your Supra Dealer. However, if a problem cannot be handled by the Dealer or if a solution is not satisfactory to you as an Owner, please follow these steps to get the matter resolved:

### STEP ONE

Discuss the problem with a member of your Supra Dealer's management staff. It is most likely that the problem will be resolved at this level.

### STEP TWO

If the Dealer management does not resolve the problem to your satisfaction, please have the problem and all action taken, documented by the Dealer, then contact the factory Customer Service Representative at Skier's Choice, Inc.:

Skier's Choice, Inc.  
5820 Highway 411 South  
Maryville, TN 37801  
Tel: (865) 856-3035  
Fax: (865) 856-3241

Describe the original problem in detail to the Customer Service Representative. Be prepared to furnish appropriate documentation and the reasons why service by the Dealer was unsatisfactory. If further action is required to resolve the problem, the Customer Service Representative will dictate the appropriate action.

### STEP THREE

Finally, if after following these steps and providing documentation and after obtaining necessary authorization from the Customer Service Representative to take additional action, the problem is still not resolved to your satisfaction, the President of Skier's Choice, Inc. will personally review the problem and make a determination concerning final resolution.

# Index

## A

Accessory Power Switch ..... 29

## B

Battery & Cable Installation ..... 50  
Battery Box ..... 35  
Battery Specifications ..... 56  
Bilge Inspection Plate ..... 34  
Bilge Pump ..... 27  
Bilge Pump Switch ..... 27  
Blower ..... 27  
Blower Switch ..... 27  
Boat Specifications ..... 6  
Body Lubrication ..... 49  
Bow Eye ..... 34  
Bow Light ..... 33

## C

Canvas Cover ..... 19  
Coast Guard Regulations ..... 20  
Cooling Systems ..... 49

Courtesy Lights ..... 28, 32  
Customer Assistance ..... 60

## D

Dealer's Responsibilities ..... 59  
Driver Seat ..... 31  
Dry Storage ..... 18

## E

Engine Data ..... 55  
Engine Hour Gauge ..... 22  
Engine Hours ..... 22

## F

Fiberglass Care ..... 52  
Filling Fuel Tank ..... 41  
Fire Extinguisher ..... 43  
Foreign Material Deposits ..... 53  
Fuel ..... 25, 41  
Fuel Cap Key ..... 30  
Fuel Filter ..... 51  
Fuel Gauge ..... 25  
Fuel Information ..... 3  
Fuel Precautions ..... 41  
Fuel Tank ..... 41  
Fuel Vent ..... 43

## H

Hoisting ..... 17  
Horn ..... 28  
Hull Identification Number ..... 54  
Hull Protection ..... 53

## I

Ignition ..... 24  
Ignition Key ..... 30  
Interior Lights ..... 28

## L

Lifting Rings ..... 33

## M

Maintenance Chart ..... 46  
Maximum Capacities ..... 20  
Mirror ..... 31

## N

Navigation Lights ..... 29  
Neutral Lock Out ..... 23

<b>O</b>			
Oil Dipstick .....	26	Speedometer .....	22
Oil Level Check .....	47	Speedometer Paddle Wheel .....	39
Oil Pressure Gauge .....	26	Starting & Operation .....	15
Oil Specifications .....	45	Stern Light .....	33
Oil Pressure .....	24		
<b>P</b>		<b>T</b>	
Propeller .....	38	Tachometer .....	22
Propeller Precaution .....	39	Temperature .....	25
		Temperature Gauge .....	25
<b>R</b>		Throttle Lever .....	23
Rub Rail .....	52	Tilt Steering .....	40
		Trailer .....	11
<b>S</b>		Boat Hook Up .....	11
Safety Procedures .....	20	Loading Procedure .....	13
Seat Adjustment .....	31	Trailer Alignment .....	11
Service & Maintenance .....	44	Unloading Procedure .....	12
Shaft Log Packing Nut .....	49	Transmission .....	47
Ski Locker .....	37	Fluid Check .....	47
Ski Platform .....	38	Fluid Specifications .....	47
Ski Pylon .....	36		
Slalom Course Speeds .....	21		
		<b>U</b>	
		Upholstery Care .....	53
		<b>V</b>	
		Voltmeter .....	26
		<b>W</b>	
		Winterization .....	18





Warranty is VOID if Registration Card is not completed and returned to Skier's Choice, Inc. with 15 days of purchase date.

---

---

---

---

PLACE  
STAMP  
HERE

**Skier's Choice, Inc.**  
5820 Highway 411 South  
Maryville, TN 37801